

MASTERING YOUR

BERNINA® *Electronic 1008*

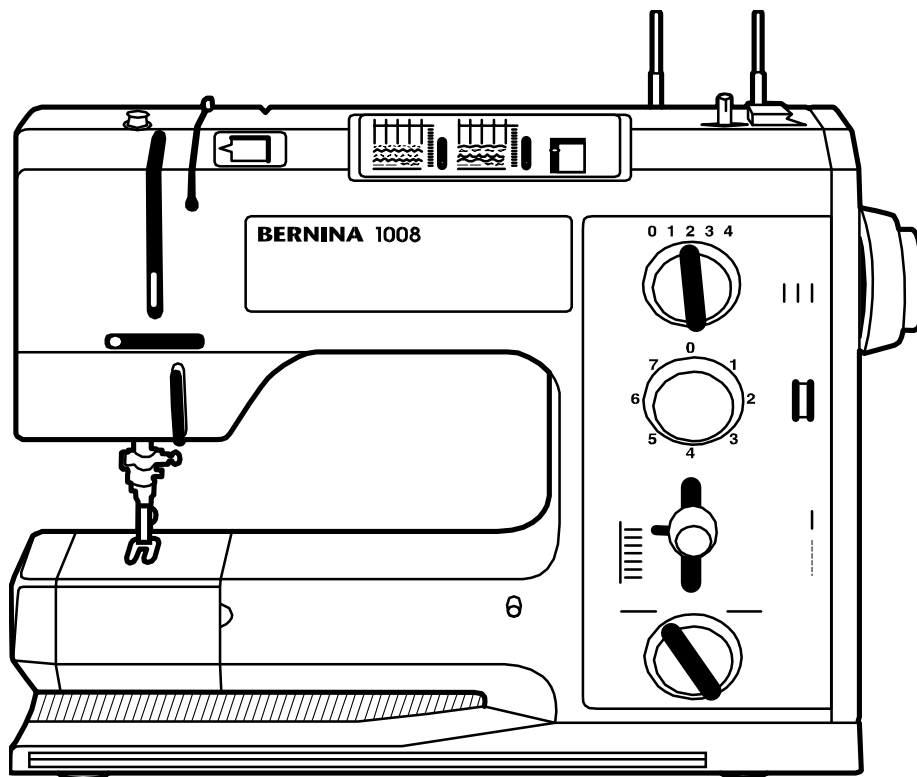

OWNER'S WORKBOOK

Table of Contents

SECTION A Pages 3-15
Care and Feeding of Your Machine

SECTION B Pages 16-30
Let's Start With The Basics

SECTION C Pages 31-47
On The Edge

SECTION D Pages 48-61
Gather It Up and Tuck It Down

MASTERING YOUR

BERNINA® *Electronic 1008*

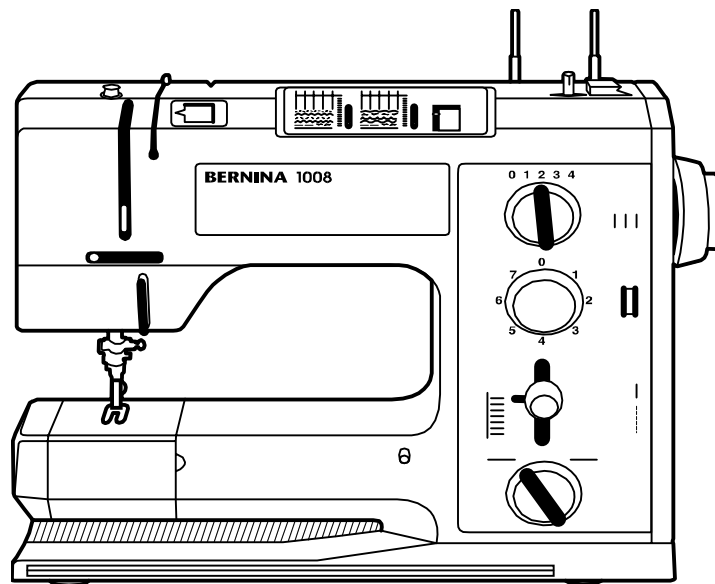

OWNER'S WORKBOOK

Section A

Care and Feeding of Your Machine

SECTION A

Care and Feeding of Your Machine

Machine Set Up

Owner's manual pg. _____

- Storage of accessories
- Attach cords foot control and machine
- Power switch – light on/off function
Owner's manual pg. _____
- Extension table (optional)

Presser Feet

Owner's manual pg. _____

- Importance of using the correct foot
- Stitch selection lever
- Overview of included presser feet
- Can also use one-piece BERNINA® presser feet

Feed Dog

Owner's manual pg. _____

Threads

Owner's manual pg. _____

- Types of thread
- Uses for each type of thread

Needles

Owner's manual pg. _____

Bobbins

Owner's manual pg. _____

- Removing the bobbin case
- Winding a bobbin
- Use bobbin thread cutter
- Clip the thread close to the case before removing the bobbin

Threading the Upper Thread

Owner's manual pg. _____

- Two vertical spool pins – Owner's manual pg. _____
- Optional supplementary thread guide
- Optional BERNINA® thread stand
- Thread machine with the presser foot **up** until ready to thread the needle

Threading the Needle

- Side thread cutter – Owner's manual pg. _____
- After the needle is threaded, put the thread under the presser foot
- Lower the presser foot
- Insert the thread into the cutter; it is cut to the proper length to begin sewing

Needle Positions

Owner's manual pg. _____

- Five positions

Practical/Decorative Stitches

Owner's manual pgs. _____

- Stitches built into the machine
- Uses for the stitches – Owner's manual pgs. _____
- How to select stitches – Owner's manual pgs. _____
 - selection lever
 - red vs. green stitches

Straight Stitching

- Seam measuring – stitch plate marks – Owner's manual pg. _____
 - the following measurements are indicated on the stitch plate: $\frac{1}{4}$ " , $\frac{3}{8}$ " , $\frac{1}{2}$ " , $\frac{5}{8}$ " , $\frac{3}{4}$ " , and 1"
 - the horizontal lines to the far back and the line in front of the needle are $\frac{5}{8}$ " from needle
- Optional piecing guide attaches to the bed of the machine.
- Right and left seam guides and Seam Guides with Rulers are available as optional accessories for the one-piece BERNINA® presser feet
- Straight stitch throat plate available
- Basting - Owner's manual pg. _____
 - maximum stitch length and loosened the needle tension helps in removal of stitches

Topstitching/Edgestitching

Owner's manual pgs. _____

Satin Stitches

- Thread bobbin case finger to adjust tension
- Can taper while sewing
- Stabilizer – important to the success of stitches

Changing the Light Bulb

Owner's manual pg.____

Cleaning the Feed Dog

- Periodically remove thread fluff and fabric fuzz which collects under the stitch plate. Refer to manual for step-by-step instructions (pg.____).

Cleaning and Lubricating the Hook

- See Owner's manual page ____ for step-by-step cleaning and oiling instructions

Cleaning the Outside of the Machine

- Wipe with damp cloth. If needed, use a solution of water and a few drops of liquid soap.
IMPORTANT: Never use oil, alcohol, or solvents of any kind on any part of the external surface of the machine.

Here's an idea...Use your birthday month as a reminder to have your BERNINA® machine serviced. Take it to an authorized BERNINA® technician during the month of your birthday and you'll never have to remember when it was last serviced.



THREADS

Poor quality or the wrong type of thread can cause poor stitches on any machine. Thread passes through the eye of the needle approximately 37 times in a “see-saw” action before it forms a single stitch. Poor quality thread results in crooked and looped stitches, puckered seams, frayed thread, and/or needle breakage. To achieve quality stitches, a sewing machine needs three things: correct thread, correct size needle, and properly adjusted thread tensions.

Several factors such as the fiber, twist, ply, finish, and size of thread must be considered for use with today’s fabrics for fine stitches.

Staple – refers to the length of fibers used to twist together to form a single ply. Domestic thread fiber lengths are usually 1½” to 2½” long while European threads use 5½” to 6½” lengths.

Ply – the number of single strands twisted together to make a single thread.

Roll – the tendency of thread to roll to the right or left during stitching, causing the stitch to appear slightly crooked. Poor quality threads are more likely to roll.

Twist – the crimping of fibers which causes them to interlock firmly into a single ply. Thread should not untwist during stitching. This will cause skipped stitches, thread breakage, crooked stitches, and weak spots in seams.

Right twist – most American threads are twisted to the right, causing some rolling. This gives average stitch quality.

Left twist – Most commercial and imported threads are twisted to the left, giving better than average stitch quality. Left twist resists rolling and makes a larger loop for the hook point to enter, reducing skipped stitches.

Wearable art embellishment has necessitated the creation and marketing of many new thread types, such as Sulky’s rayons and metallics. Made in West Germany, these are left twist threads; Mettler and Isacord threads are also left twist. To test the twist of a thread: while holding the spool in the left hand, roll the strand of thread towards you with one thumb. Left twist will tighten, right twist will loosen.

Fiber – refers to the type of material used to produce the thread. Some commonly used threads:

- *Polyester 2 ply* – such as Metrosene 100. Good for clothing construction on man-made, natural or blended fabrics. Will tolerate heat up to 450° Fahrenheit. Also Isacord embroidery thread – excellent for embroidery, very abrasion resistant.
- *Polyester 3 ply cordonnet* – topstitching or buttonhole twist – such as Mettler 30/3.
- *Cotton 2 ply* – such as Mettler 60/2 – excellent for French Machine Sewing, delicate machine embroidery, and darning.
- *Cotton 2 ply* – such as Mettler 30/2 – loose twist for a soft, shiny look in machine embroidery, applique, and buttonholes.
- *Cotton 3 ply* – such as Mettler 50/3 – excellent for clothing construction on natural fibers. Tighter twist than embroidery cotton thread and less puckering on problem fabrics. Cotton thread stretches less than polyester.
- *Rayon* – a lustrous embroidery thread. Weaker than cotton, it is used for decorative work only.

NEEDLES

Along with thread, needles are very important to stitch formation. Many “mechanical” problems and damage to fabrics can be traced to a bent, damaged, or incorrect size or type needle. Approximately 60% of all needles made are discarded at some stage of production. When selecting the correct needle for any sewing project, three things must be considered:

Needle system – 130/705H

Needle point – to assure stitch formation and avoid fabric damage

Needle size – small size for lightweight fabrics; larger needle for heavier fabrics

If the needle is:

Too small – the thread can't stay in the groove to form a loop to be picked up by the hook point

Bent – thread loop forms too far away from hook point; hook can't enter loop to form stitch

Blunt – needle won't pierce fabric so no thread loop forms to make a stitch

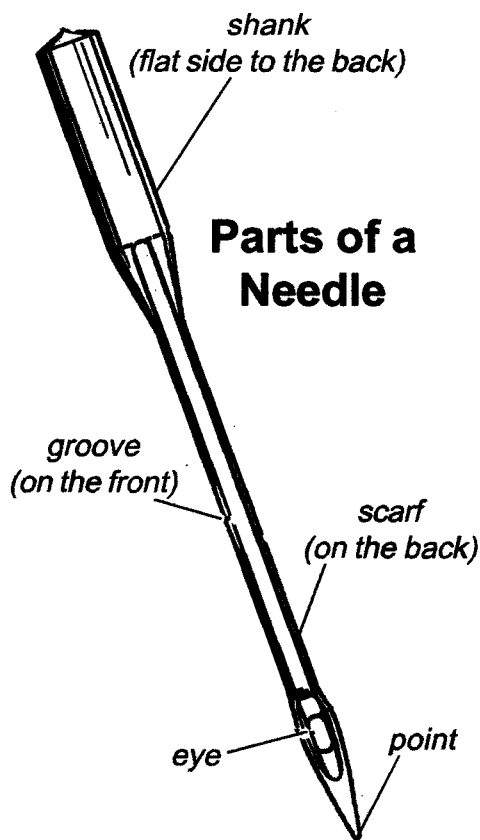

Need To Know

- Needle should be changed every 4-6 hours of sewing. The needle is the most inexpensive part in your sewing machine but is one of the most crucial for getting good results and keeping your machine running well. Don't let false economy keep you from doing what is best for your sewing projects and your machine.
- European needles are chrome-plated to glide in and out of fabric easily.
- The selected thread should fit in the groove on the front of the needle. If it isn't protected by the groove, a needle with a larger groove should be used.
- Always make sure the needle is fully inserted as high as possible when installing a new one.

SEWING MACHINE NEEDLES

| | | | | | |
|--------------------------|--------------------|---|---------------------------------|--------------------|---|
| Ball Point | 70-90 | Has a rounder point. 70 for lingerie, nylon, jersey; 80 for T-shirt; 90 for sweatshirt fleece. | Microtex Sharp (Schmetz) | 60-90 | A sharp point with a thin shaft. 60-90 corresponds to the weight of the fabric; as the fabric gets heavier, the number is higher. |
| Stretch | 70-90 | A stretch needle has a more rounded point and a blue anti-clogging coating which helps to prevent skipped stitches in knits and elastic. Sometimes used on Ultrasuede®, vinyl, and plastic. | Microfiber (Lammertz) | | |
| Stretch Double | 2.5/75 4.0/75 | Two ballpoint needles on one shank; each needle has a large scarf. Used for hemming and for stitching on knit fabric. | Quilting | assort'd (75 & 90) | The thin, tapered point of this needle causes less damage to fabric when seaming and cross seaming. |
| Universal | 60-110 | A compromise between a sharp and a ballpoint needle; can be used on both wovens and knits. 60 – very fine batiste 70 – broadcloth 80 – trigger and gabardine 90 – denim and twill 100 & 110 – canvas | Topstitch | 80-100 | A sharp point with a large eye and deep groove. For use with heavier fabrics – the large groove cradles heavier threads. |
| Double Universal | 1.6/70- 8.0/100 | Two needles attached to one shank. Used for pintucks, hems, and decorative work. | Embroidery (Schmetz) | 75-90 | Sharp needle with a large eye and groove; also has a coating and a larger scarf. For use with embroidery thread – prevents shredding of rayon or metallic threads. Two threads may be used through the eye of an 80 or 90 needle. |
| Triple (Drilling) | 3.0/90 | Three needles attached to one shank. Used to create mock smocking and other decorative effects. | Metafil (Lammertz) | | |
| Jeans | 70-90 | Has a sharp point and a shaft that is less prone to flex. The sharpness of the needles makes it better for use on denim and woven fabrics where a clean stitch is desired. | Metafil Double | 3.0/75 | Two Metafil needles attached to one shaft; for double needle work with embroidery threads. |
| Jeans Double | 4.0/100 | Two Jeans needles attached to one shank. For topstitching on denim with heavy thread; can also be used for decorative stitching with metallic thread. | Wing | 100-120 | Sharp pointed needle with a non-cutting wedge of metal on each side. Needle makes a hole in the fabric without cutting the threads of the fabric. Used for decorative and heirloom work, such as hemstitching. Works best on natural fibers or on the bias. |
| | | | Double Wing | 100 | One regular needle and one wing needle attached to a single shaft. Use the same as a Wing; makes one large and one regular hole. |
| | | | Leather | 80-90 | Point is a sharp cutting wedge. Used for sewing leather only. Not for vinyl or simulated leathers. |

NEEDLE POSITIONS

| | |
|----------------------|---|
| Fabric: | Firmly woven fabric, 4" x 6" |
| Needle: | 90/14 Embroidery |
| Thread: | 30 wt. cotton embroidery Contrasting color |
| Presser Foot: | Reverse Pattern Foot #1 |

Owner's manual pg. ____

- The 1008 has 5 fixed needle positions.
- Fold fabric in half to 2" x 6".
- Select Straight Stitch. The needle position can be set to the left or right using the knob in the center of the stitch width knob.
- Position the fold of the fabric on the 1" mark on the right side of the stitch plate.
- Sew about 6 stitches and stop.
- Move the needle one position to the left.
- Sew another 6 stitches and stop again.
- Repeat until all three positions have been sewn.
- Raise the needle out of the fabric. Leaving the fabric under the foot – move the needle position back to center.
- Sew about 6 stitches and stop.
- Move the needle one position to the right.
- Sew about 6 stitches and stop.
- Move the needle one more position to the right – sew another 6 stitches and stop again.
- Repeat until all three positions have been sewn.

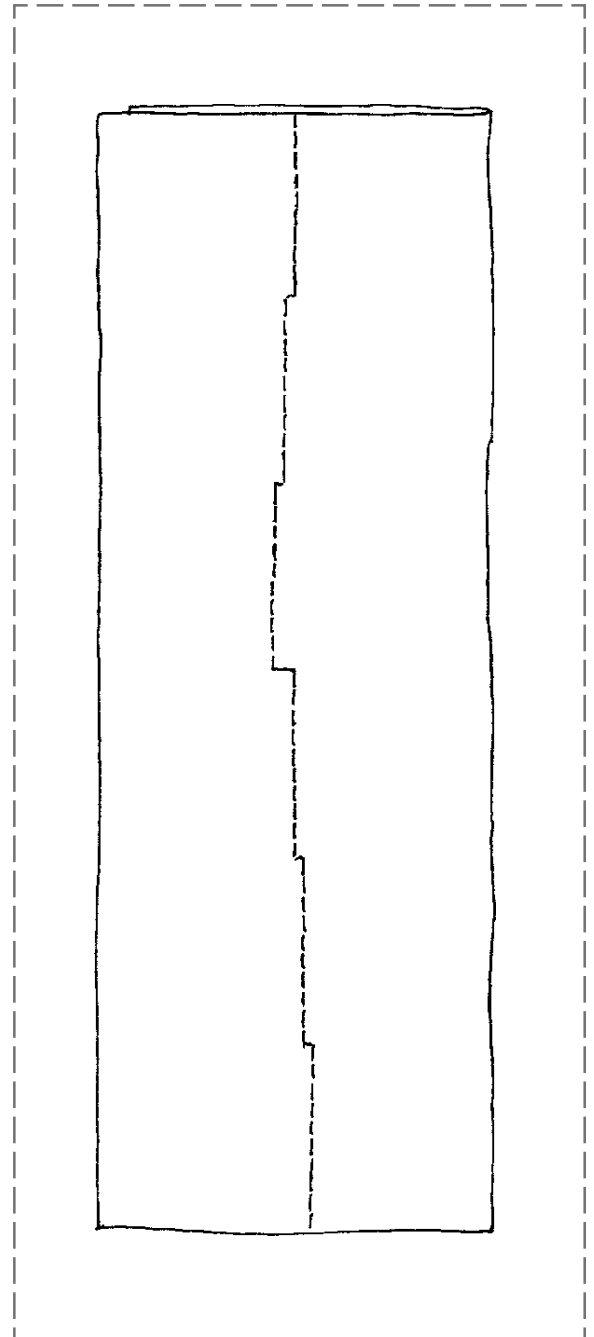

SEAMING

| | |
|----------------------|---|
| Fabric: | Firm fabric – 2 pieces, 4" x 6" each |
| Needle: | 90/14 Embroidery |
| Thread: | 30 wt. cotton embroidery Contrasting color |
| Presser Foot: | Reverse Pattern Foot #1 |

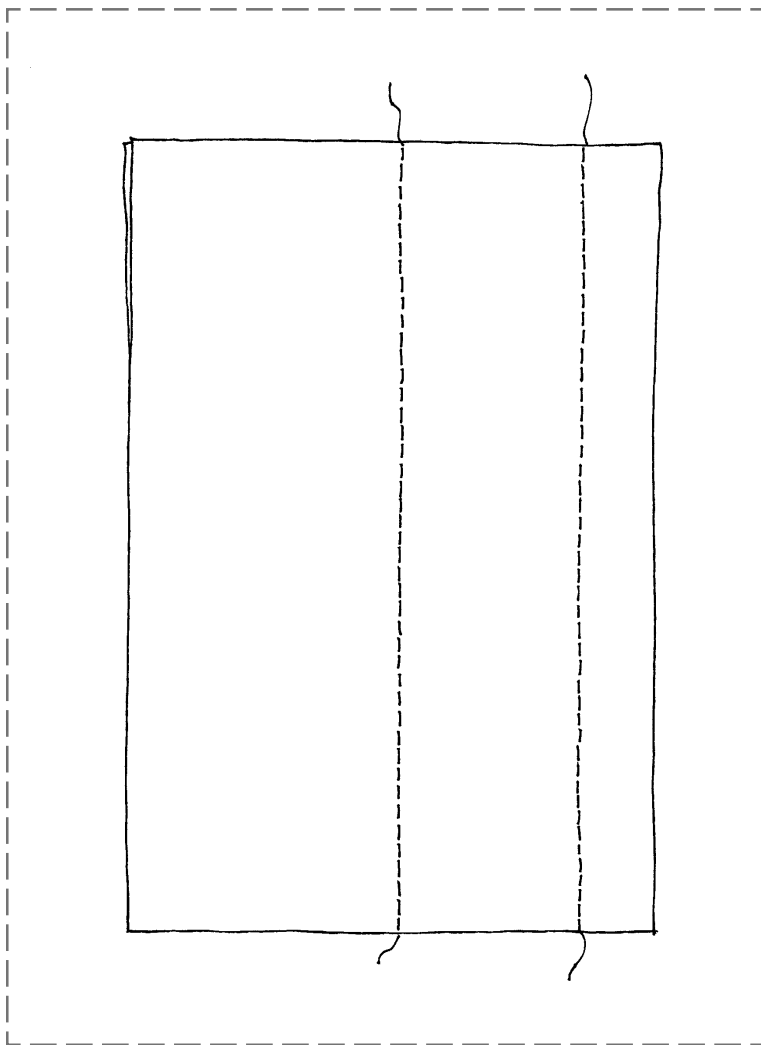

Owner's manual pg. ____

- Find the $\frac{5}{8}$ " guide line on the stitch plate.
- Place fabric pieces right sides together and align them with the guide line.
- Sew a $\frac{5}{8}$ " seam on one 6" edge.
- Sew a 2" seam along the opposite edge.

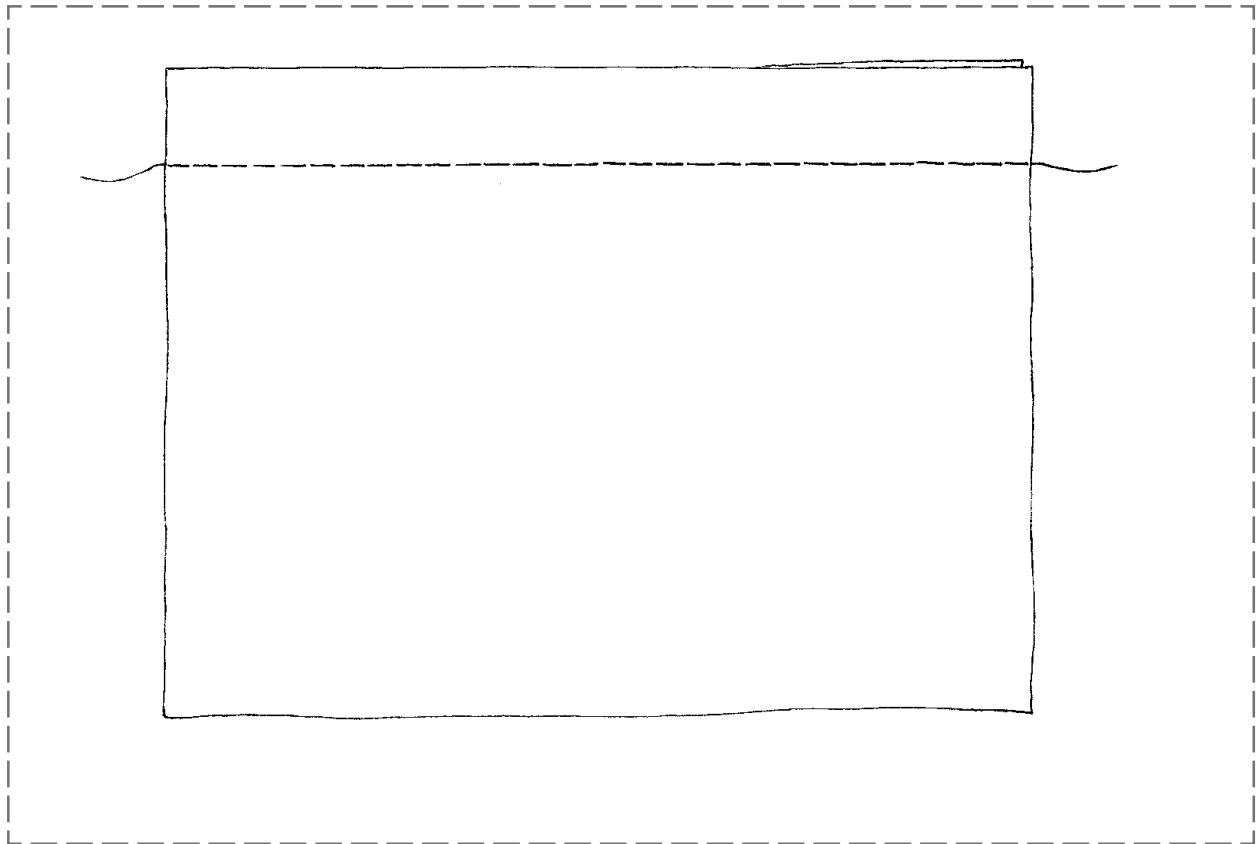

BASTING

| | |
|----------------------|---|
| Fabric: | Firm fabric – 2 pieces, 4" x 6" each |
| Needle: | 90/14 Embroidery |
| Thread: | 30 wt. cotton embroidery Contrasting color |
| Presser Foot: | Reverse Pattern Foot #1 |

Owner's manual pg. ____

- Place fabric pieces right sides together.
- Select Straight Stitch #1; adjust the length to 5mm
- Baste a $\frac{5}{8}$ " seam along one edge of the fabric.

Note: Loosening the top tension makes the stitches easier to remove.

TOPSTITCHING/EDGESTITCHING

| | |
|----------------------|---|
| Fabric: | Firm fabric – 4" x 6" |
| Needle: | 90/14 Embroidery |
| Thread: | 30 wt. cotton embroidery Contrasting color |
| Presser Foot: | Edgestitch Foot #10 (optional accessory) |

Owner's manual pg. ____

- Cut fabric in half to create 2 pieces each 2" x 6".
- Sew two pieces together with a $\frac{5}{8}$ " seam on the 6" sides.
- Press the seam open.
- From the right side, position the blade of the foot in the ditch of the seam.
- Select Triple Straight Stitch #9/red.
- Move the needle position 1 place to the left (half left).
- Sew the length of the seam.
- Select the longest stitch length.
- Move the needle position 2 places to the right (far right).
- Start at the top of the seam as before.
- Sew down the length of the seam again.

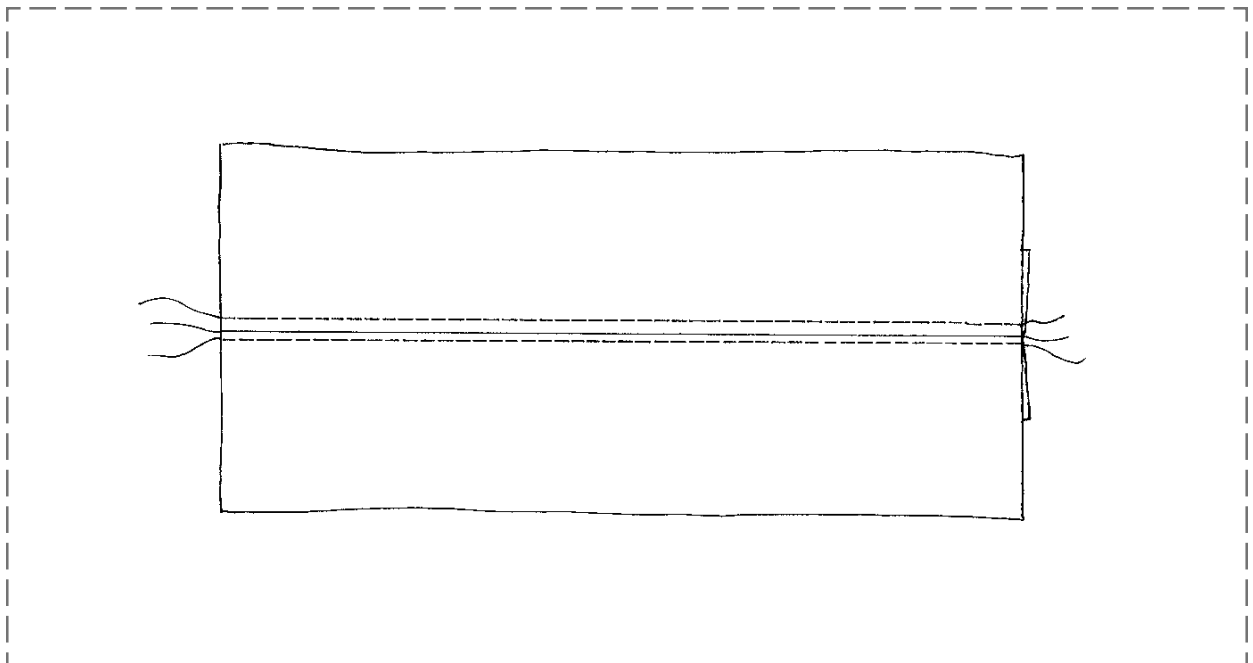

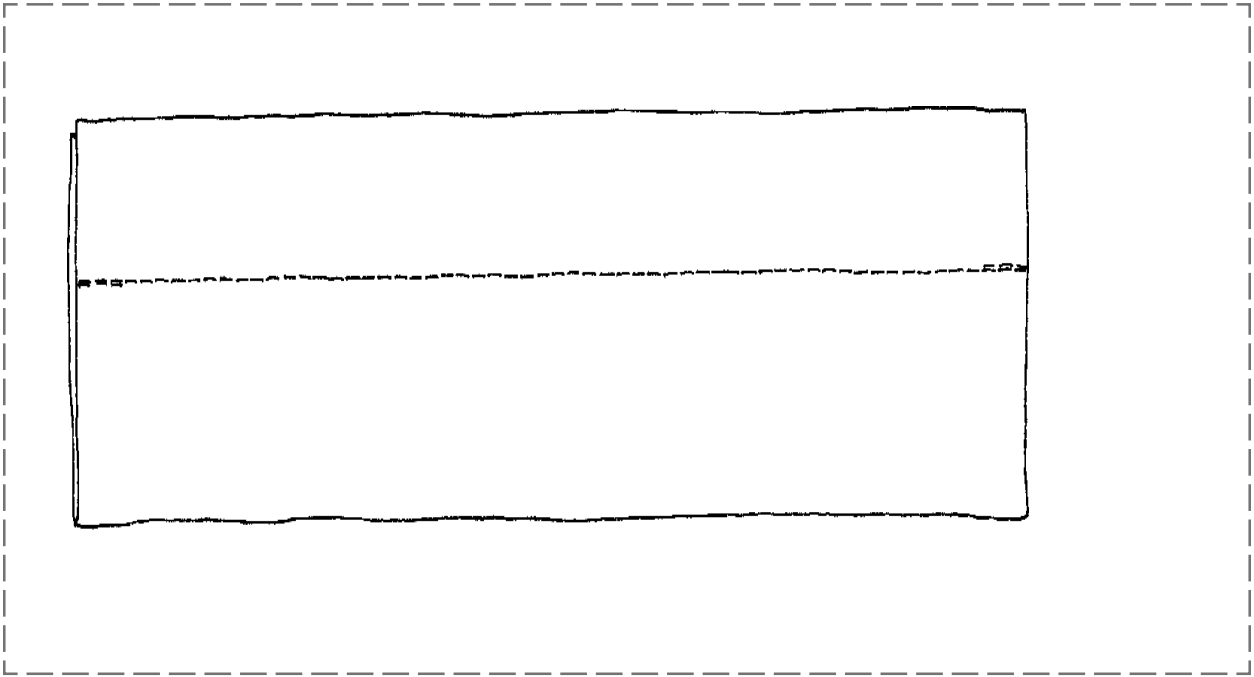

SECURING STITCHES

| | |
|----------------------|--------------------------|
| Fabric: | Firm fabric, 3" x 6" |
| Needle: | 90/14 Embroidery |
| Thread: | 30 wt. cotton embroidery |
| Presser Foot: | Reverse Pattern Foot #1 |

Owner's manual pg. _____

- Fold each fabric piece in half to 1½" x 6".
- Find the 5/8" seam line on the guide plate.
- Select Straight Stitch #1/green and sew a few stitches.
- Engage the Reverse Lever for about 3/8"; the machine will sew in reverse as long as the lever is engaged.
- Continue stitching the seam and secure the end in the same manner.

SATIN STITCH

| | |
|----------------------|--------------------------------------|
| Fabric: | Firm fabric – 2 pieces, 3" x 6" each |
| Needle: | 90/14 Embroidery |
| Thread: | 30 wt. Cotton Embroidery |
| Presser Foot: | Reverse Pattern Foot #1 |

Owner's manual pg. ____

- Fold fabric in half to 3" x 6". Use stabilizer as needed.
- Select Zigzag Stitch #2/green. Change the stitch length to satin stitch and the stitch width to 5.5mm.
- Thread the bobbin thread through the hole in the finger of the bobbin case.
- Move the needle position all the way to the left.
- Position the raw edge of the fabric on the $\frac{3}{8}$ " line (on the right side of the stitch plate).
- Sew down this edge about 1". While continuing to sew, turn the stitch width knob to taper the stitch to 0mm. Then widen the stitch back to maximum. Repeat until the stitching reaches the end of the fabric.
- Position the fold of the fabric on the $\frac{3}{8}$ " line (on the left side of the stitch plate).
- Move the needle position all the way to the right and stitch along the right side of the fabric, tapering and widening the stitching while sewing.
- Move the needle position to the center and stitch down the center of the fabric, tapering and widening the satin stitch while sewing.

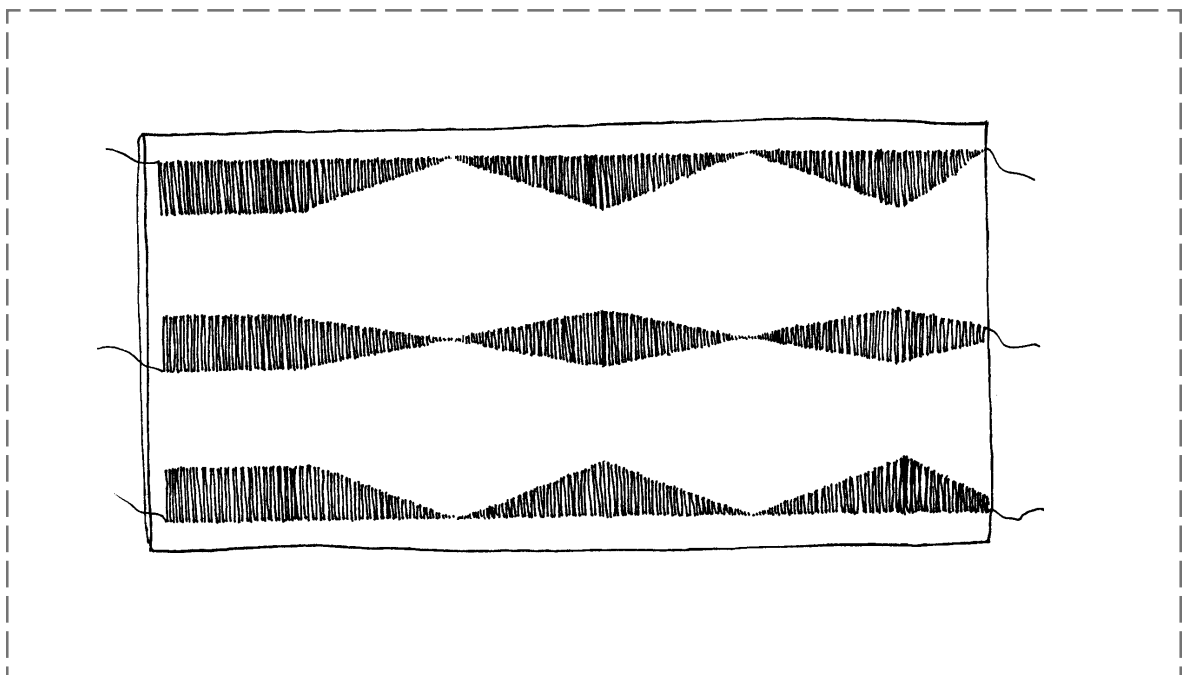

WISH LIST

Care and Feeding of Your Machine

- Hard Case
- Slide-on Extension Table with Guide
- Feet-ures
- Edgestitch Foot #10
- Stabilizers – Sampler Pack or type _____
type _____
- Thread – Assortment or size _____ and type _____
size _____ and type _____
- Needles – Assortment or size _____ and type _____
size _____ and type _____
size _____ and type _____
size _____ and type _____
- Needle Threader
- Bobbins – Baker’s dozen
- Spool Bobbin Holders
- Magnetic Pin Cushion
- Magnetic Bobbin Holder
- Straight Stitch Plate
- Seam Sealant
- Extra Thread Stand
- Scissors - 6” or 7” Dressmaker’s shears _____
4” or 5” Trimming scissors _____
Thread nips _____
- Left guide (matches right guide included with machine)_____
- Right and Left Seam Guides with Rulers
- Set of Magnifying Glasses

MASTERING YOUR

BERNINA® *Electronic 1008*

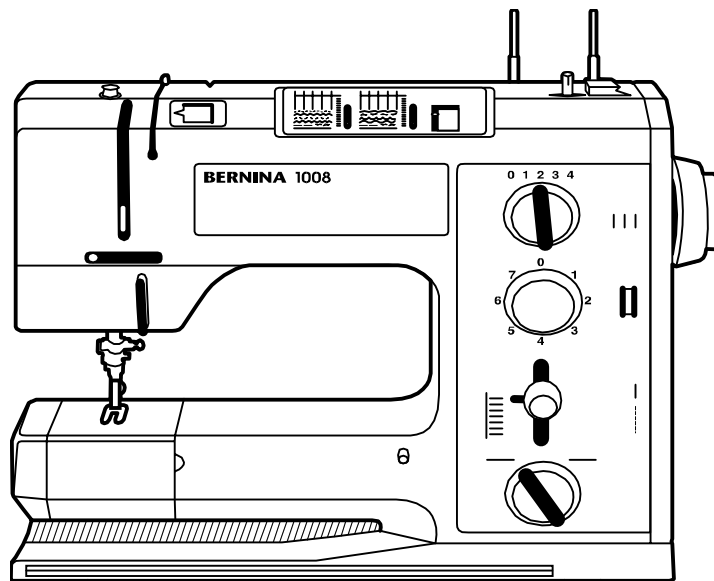

OWNER'S WORKBOOK

Section B

Let's Start With The Basics

SECTION B

Let's Start With The Basics

Seams

Triple Straight Stitch – SL 2-3mm

Owner's manual pg. ____

- Jeans Foot #8 prevents needle deflection
- Non-Stick Straight Stitch Foot #53
- This stitch sews strong seams on heavy fabrics

Zigzag – SL1mm SW1.5mm

Owner's manual pg. ____

Vari-Overlock – SL1mm SW4mm NP right

Owner's manual pg. ____

- Can be used with double needle for a decorative hem on knits
- Overlock Foot #2 prevents the seam from rolling as it is being sewn

Double Overlock – SL2mm SW5mm

Owner's manual pg. ____

Flat Joining Seam - SL2mm SW4mm

Owner's manual pg. ____

Stitching Corners

- Use the $\frac{5}{8}$ " markings on stitch plate.
- Turn handwheel counter clockwise to sink needle into fabric.

Oversewing Edges

Owner's manual pg. ____

Hems

Blind Hem – Owner's manual pg. ____

- The Blind Hem Foot #5, along with the blindstitch, produces a superior blind hem. The zigzag part of the stitch is formed over the guide on the foot, causing the stitch to be slightly loose, so that the blind hem will not pucker and does not form a tuck in the fabric.

Hand Picked – *Feet-ures*, Unit B pg. ____

Triple Zigzag – *Feet-ures*, Unit A pg. ____

- This stitch is used for strong, visible hems on firm, coarse fabrics such as denim and canvas.

Double Needle – *Feet-ures*, Unit A pg. ____

Neckline Hem – Owner's manual pg. ____

Jeans – *Feet-ures*, Unit B pg. ____

- Height Compensation Tool

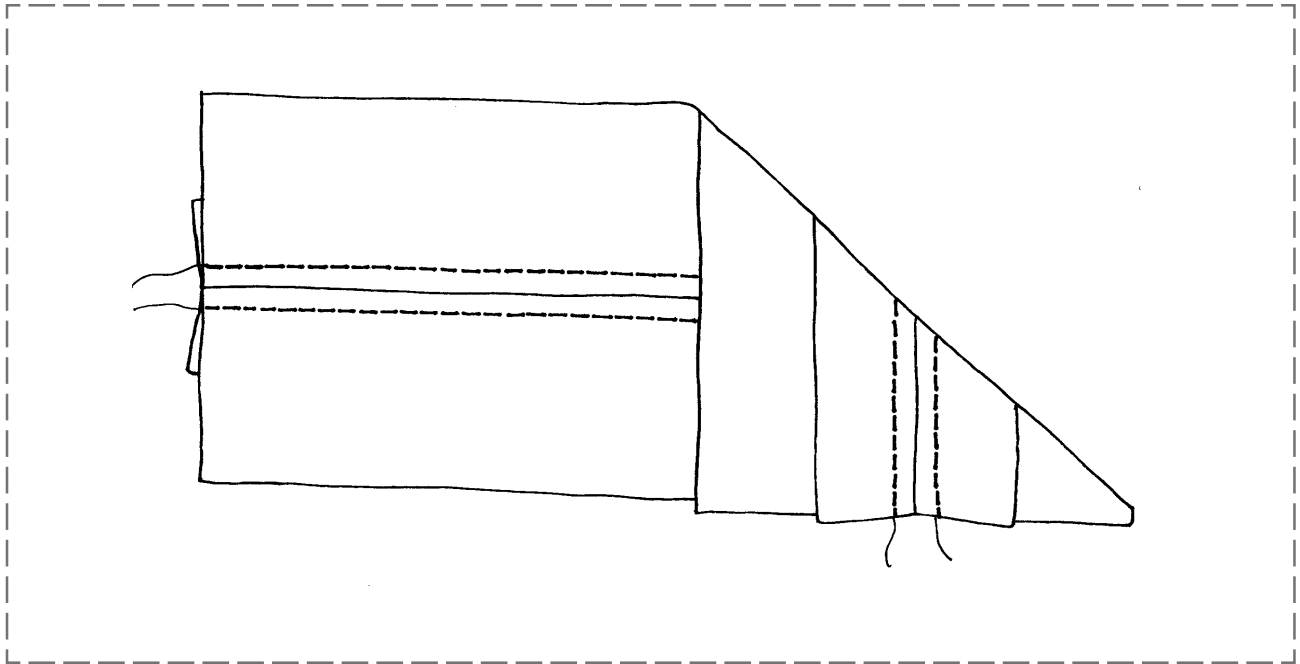

TRIPLE STRAIGHT STITCH

| | |
|----------------------|---|
| Fabric: | Denim, 4" x 6" |
| Needle: | 90/14 Jeans |
| Thread: | All-purpose |
| Presser Foot: | Reverse Pattern Foot #1 Edgestitch Foot #10 (optional accessory) |

Owner's manual pg.____

- Cut the fabric in half lengthwise forming two pieces, 2" x 6" each.
- Select the Triple Straight Stitch #9/red.
- Sew the two pieces together with a $\frac{5}{8}$ " seam allowance using Reverse Pattern Foot #1.
- Press the seam open.
- Change to Edgestitch Foot #10 and adjust the needle position to stitch through the seam allowance.
- Adjust the stitch length to 3.5mm.
- With the guide of the foot in the ditch of the seam, topstitch the length of the seam on both sides.

ZIGZAG SEAM

| | |
|----------------------|-------------------------|
| Fabric: | Firm knit – 4" x 6" |
| Needle: | 80/12 Universal |
| Thread: | All-purpose |
| Presser Foot: | Reverse Pattern Foot #1 |

Owner's manual pg. ____

- Cut the fabric piece in half lengthwise, creating two pieces, 2" x 6" each.
- Select the Zigzag Stitch #2/green – SW 1mm and SL 0.5mm.
- Position the fabric to produce a $\frac{5}{8}$ " seam down one side.
- Stitch the seam.
- Clip one seam allowance in the middle.
- Press one part of the seam open and leave the other half closed, so the stitch is visible.
- Trim and mount the sample.

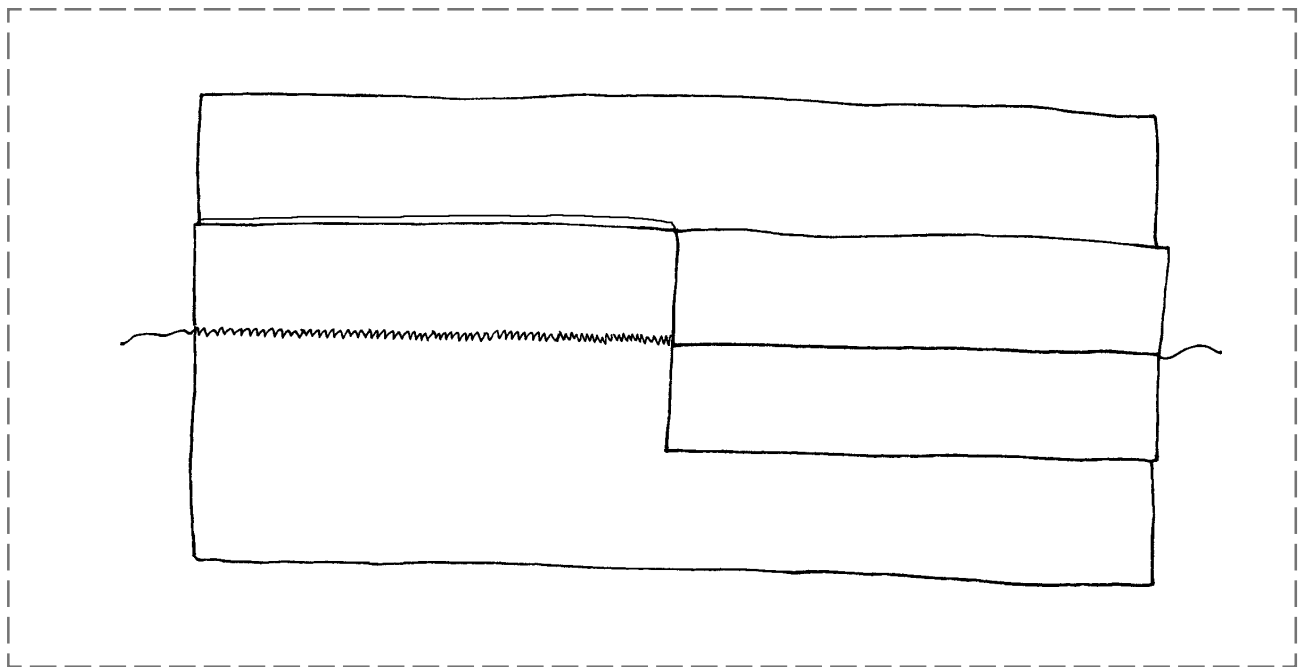

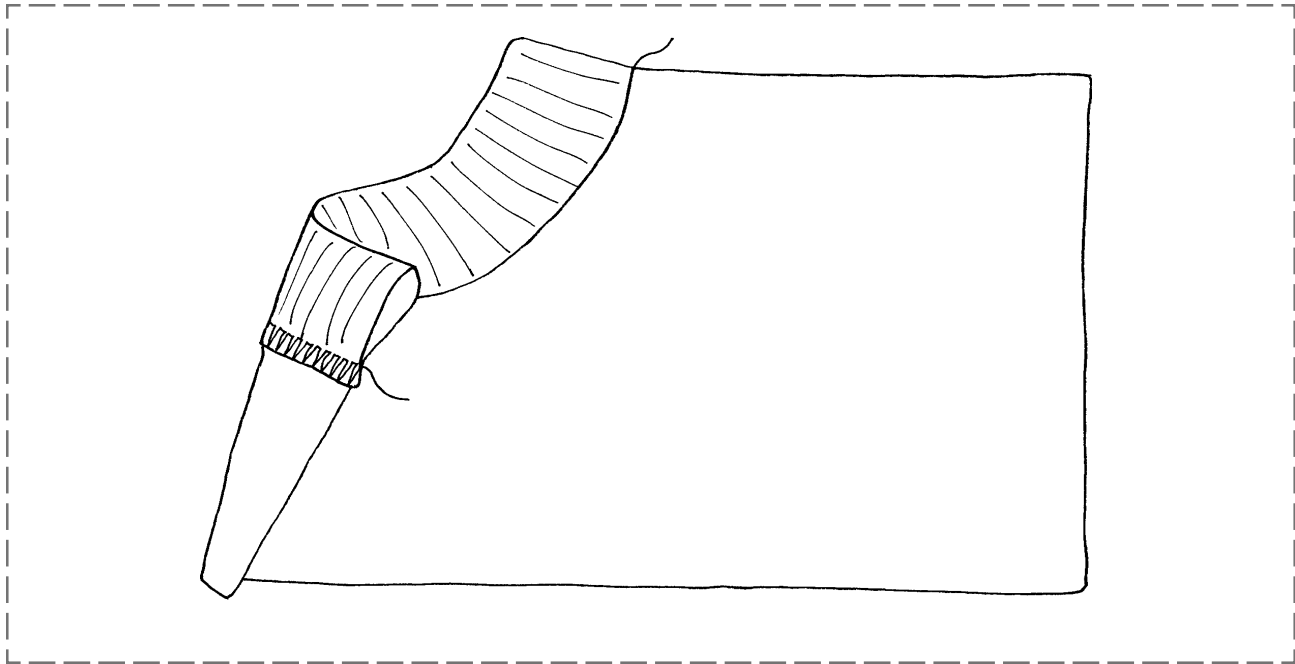

VARI-OVERLOCK SEAM

| | |
|----------------------|---|
| Fabric: | Cotton Interlock, 4" x 6" Ribbing, 2" x 4" |
| Needle: | 80/12 Universal |
| Thread: | All-purpose |
| Presser Foot: | Overlock Foot #2 |

Owner's manual pg. ___

- Cut an inside curve in one corner of the fabric to simulate a neckline.
- Select the Vari-Overlock Stitch #6/green; SW 4mm - 5mm and SL 1mm.
- Place folded ribbing along the curved edge of the fabric (ribbing and fabric, right sides together).
- Guide the raw edges of the fabric under the pin of the foot and stitch; stitch length and width can be adjusted, if needed.
- Trim the sample and mount with the ribbing pressed to the finished position.

DOUBLE OVERLOCK SEAM

| | |
|----------------------|-----------------------|
| Fabric: | Single Knit – 4" x 6" |
| Needle: | 80/12 Universal |
| Thread: | All-purpose |
| Presser Foot: | Overlock Foot #2 |

Owner's manual pg. ____

- Cut the fabric in half lengthwise, creating two pieces, 2" x 6' each.
- Select the Double Overlock Stitch #12/red.
- Guide the raw edge along the pin of the Overlock Foot.
- The right swing of the needle should go off the fabric edge.
- Trim the sample and mount.

Note: This is a good overlock seam for loosely knit fabrics and for cross seams in other knits and jerseys.

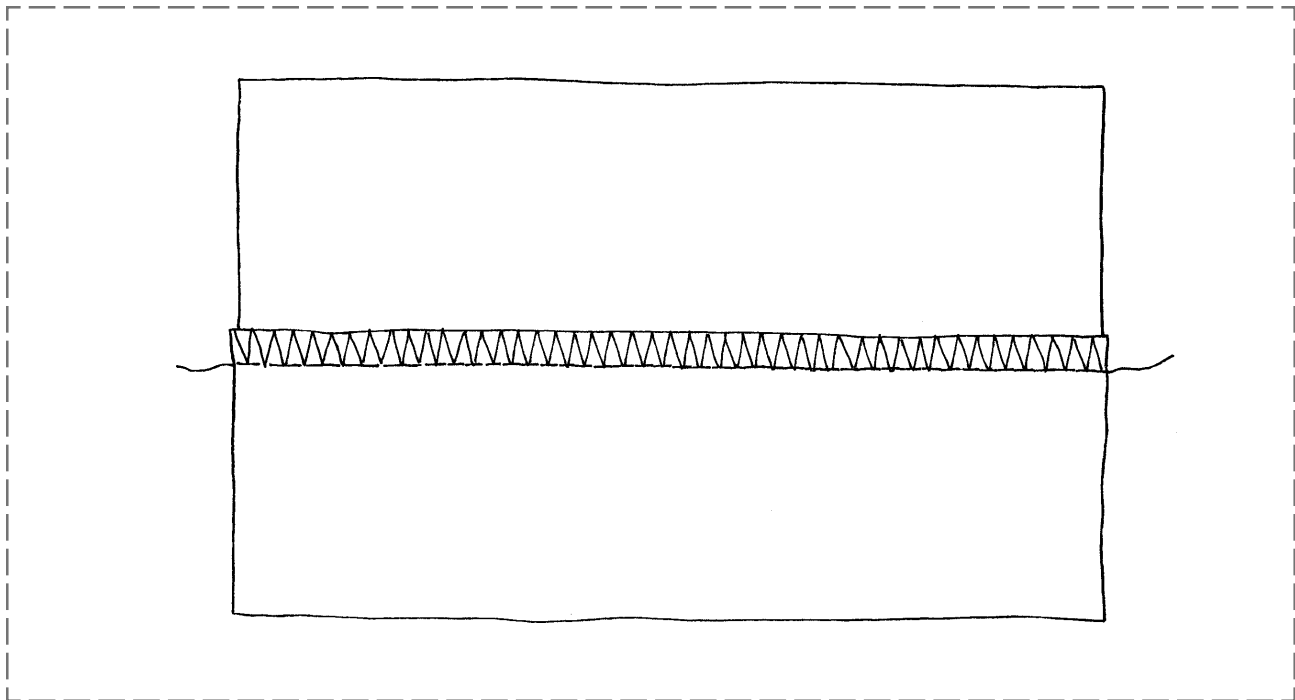

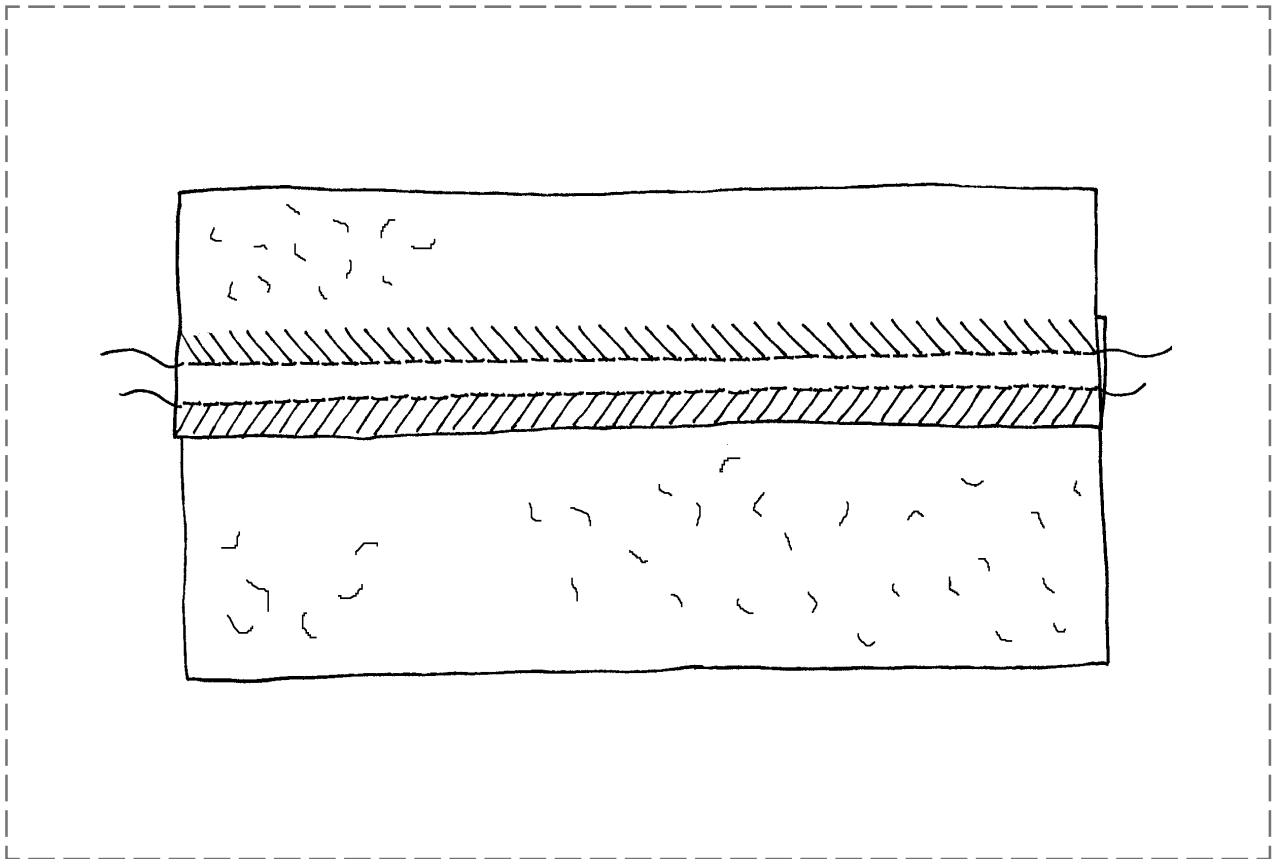

FLAT JOINING SEAM

| | |
|----------------------|--------------------------------------|
| Fabric: | Terrycloth – 2 pieces, 2" x 6" each |
| Needle: | 90/14 Universal |
| Thread: | All-purpose to match color fo fabric |
| Presser Foot: | Reverse Pattern Foot #1 |

Owner's manual pg.____

- Select the Stretch Overlock stitch #11/red.
- Cut a $\frac{5}{8}$ " seam allowance off one piece of fabric along the long edge.
- Mark a line on the other piece of fabric, $\frac{5}{8}$ " from one long edge. This will be the right-hand piece of fabric.
- Overlap the fabric edges left over right, aligning the left raw edge with the drawn line on the right-hand piece.
- Stitch along the raw edge. Turn the fabric over and stitch along the remaining raw edge.

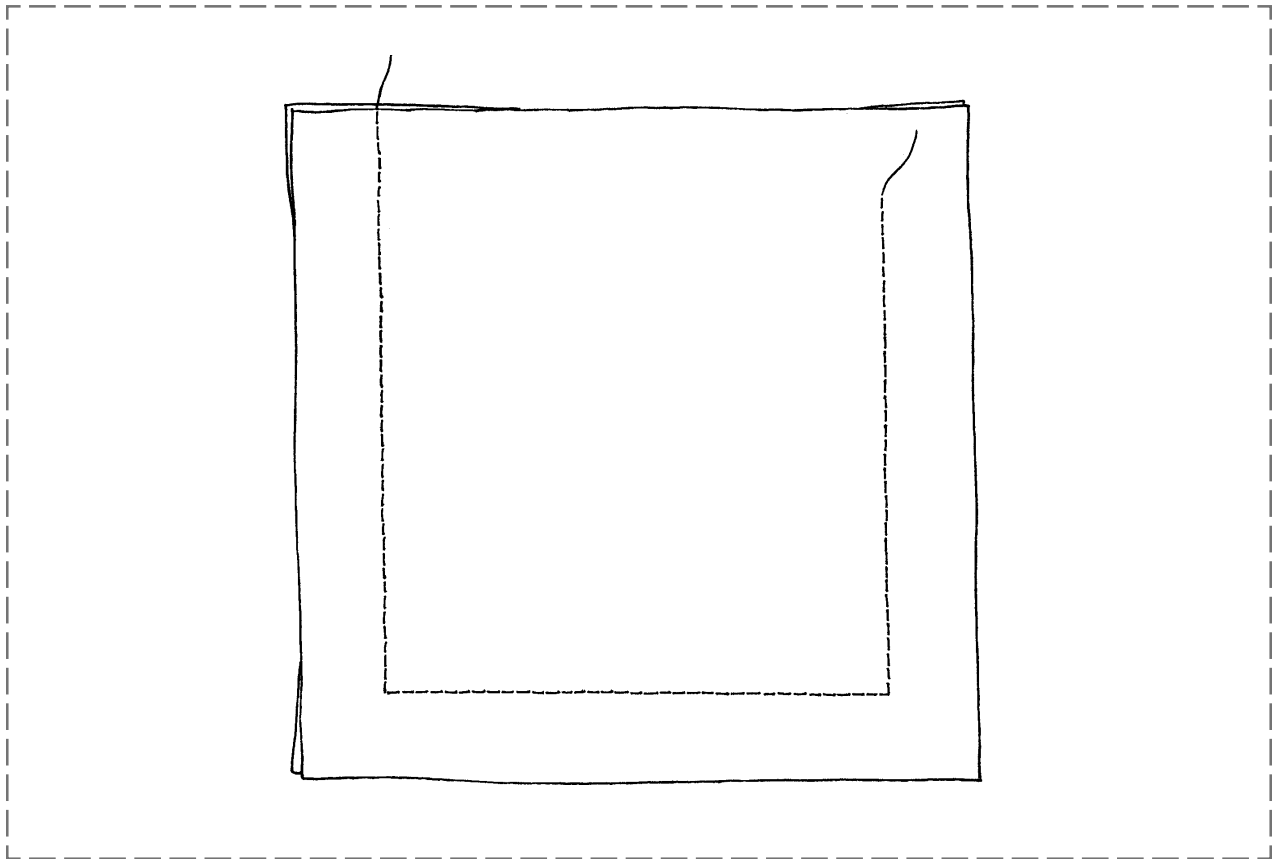

STITCHING CORNERS

| | |
|----------------------|--------------------------------------|
| Fabric: | Firm fabric – 2 pieces, 5" x 5" each |
| Needle: | 80/12 Universal |
| Thread: | All-purpose |
| Presser Foot: | Reverse Pattern Foot #1 |

Owner's manual pg. ____

- Select the Straight Stitch #1/green.
- Place fabric pieces right sides together.
- Place the fabric under the foot with the top edge even with the horizontal line behind the foot.
- The right edge should be even with the $\frac{5}{8}$ " seam line.
- Sew until the bottom edge touches the horizontal line in front of the needle; stop with the needle down.
- Pivot and continue sewing until you come to the next corner and do the same thing.
- Stitch only three sides of this sample.

OVERSEWING EDGES

| | |
|----------------------|-------------------------|
| Fabric: | Heavy Flannel – 3” x 6” |
| Needle: | 80/12 Universal |
| Thread: | All-purpose |
| Presser Foot: | Reverse Pattern Foot #1 |

Owner's manual pg. ___

- Select the Zigzag Stitch #2/green.
- Finish one 6” edge using the following steps.
- Guide edge of fabric under the middle of the presser foot.
- The needle should go into the fabric on one stroke of the needle and over the edge on the next stroke.
- Do not use too long a stitch or too wide a stitch; the edge should lie flat, not roll.
- Match the weight of the thread to the weight of the fabric.
- Trim and mount the sample.

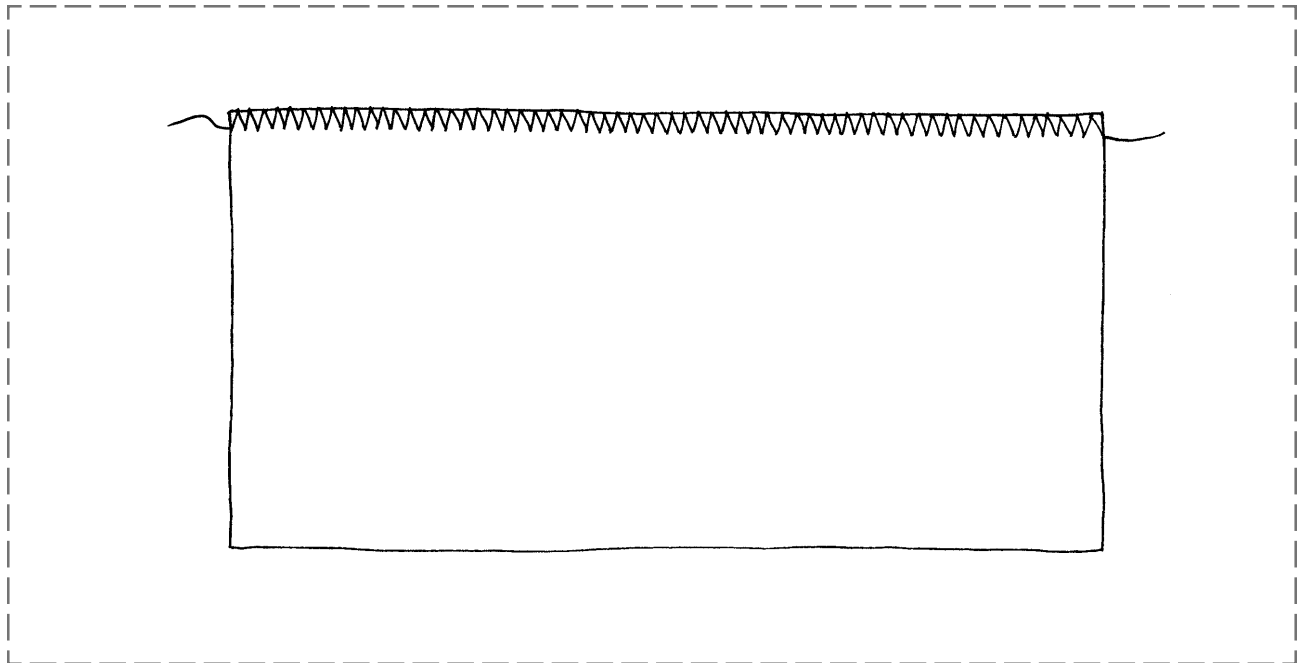

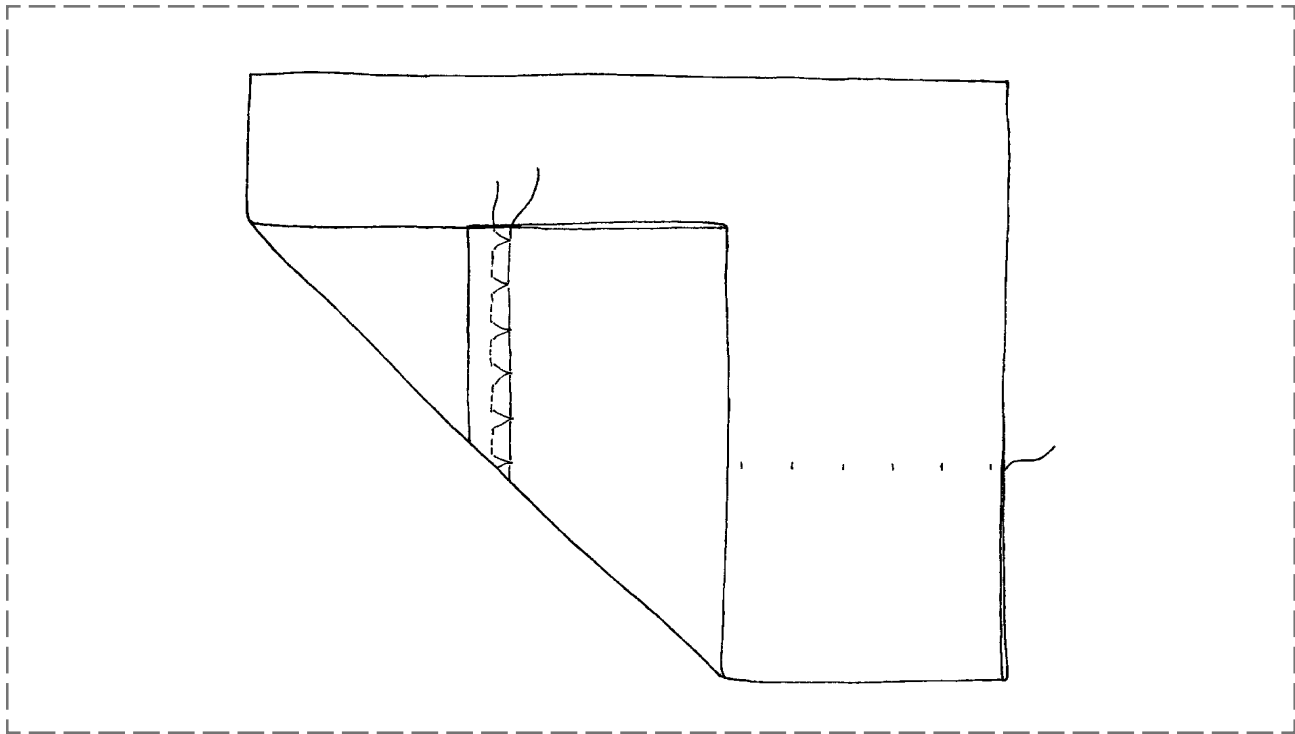

BLIND HEM

| | |
|----------------------|---|
| Fabric: | Heavy Flannel – 6" x 7" |
| Needle: | 80/12 Universal |
| Thread: | All-purpose |
| Presser Foot: | Reverse pattern Foot #1 <i>and</i> Blind Hem Foot #5 |

Owner's manual pg.____

- Finish one 6" edge of the fabric following the steps of the previous exercise.
- Fold a 2" hem to the wrong side of the fabric and press.
- Attach Reverse Pattern Foot #1.
- Baste the hem in place, sewing about ¼" from the raw edge.
- Select the Blindstitch #3/green (SW 3mm and SL 2.25mm); attach Blind Hem Foot #5.
- Fold hem back to the right side over the basting line.
- Sew on the extended hem allowance, keeping the folded edge next to the guide on the foot.
- Adjust the stitch width if needed so that the needle barely stitches into the fold.
- Mount the sample with the edges folded back as shown in the drawing.

HAND PICKED HEM

| | |
|----------------------|----------------------------------|
| Fabric: | Lightweight broadcloth – 6" x 7" |
| Needle: | 80/12 Universal |
| Thread: | All-purpose |
| Presser Foot: | Blind Hem Foot #5 |

Owner's manual pg.____

- Turn up a 1" hem along one of the 6" edges and press.
- Turn up the depth of the hem again and press.
- Fold the entire hem toward the right side of the garment, so that the garment fold is almost even with the top edge of the hem. A scant $\frac{1}{8}$ " to $\frac{1}{16}$ " of hem edge should be visible. This will ensure that both folds are caught by the blind hem pick.
- Place the fabric under the foot just as a traditional blind hem would be placed.
- Sew the hem with Blindstitch #3/green, making sure that the zigzag pick catches both folds while the straight stitch falls off the edge and stitches in air forming a chain along the upper hem edge.
- Press and mount the sample.

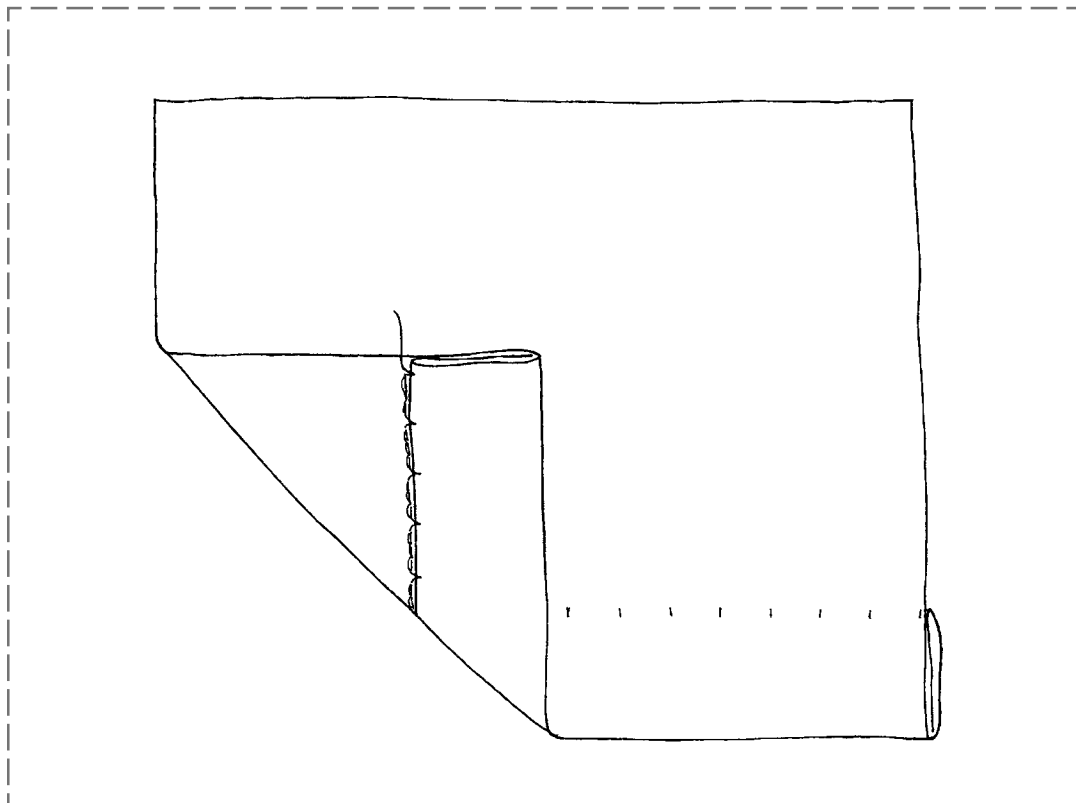

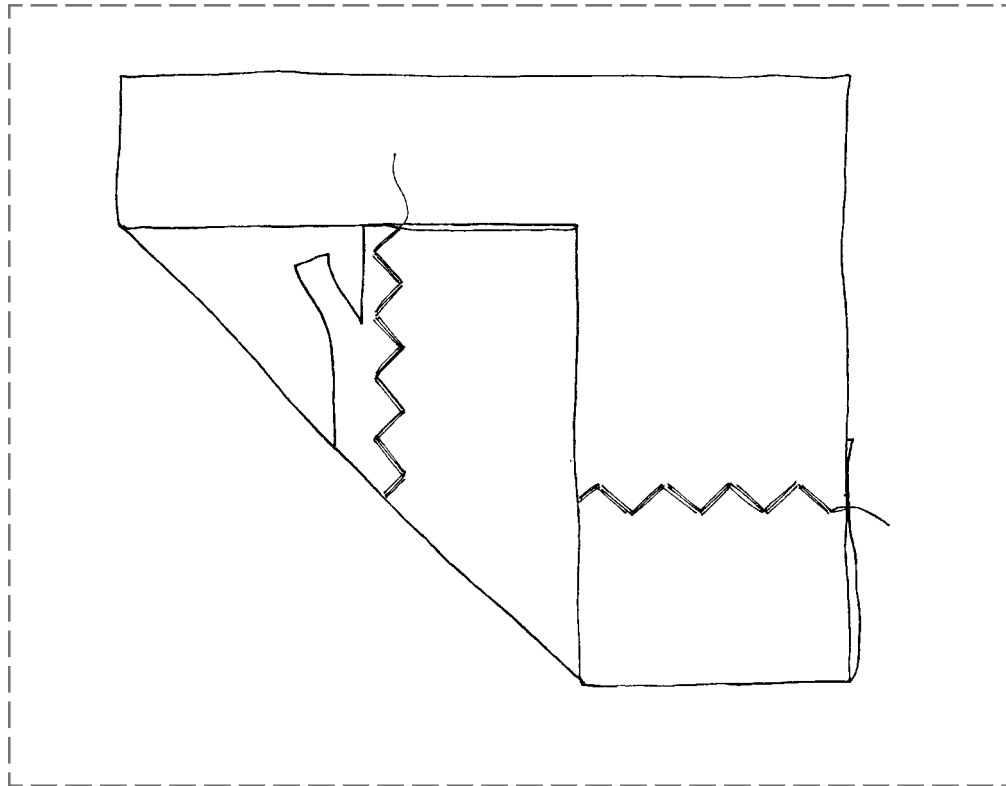

TRIPLE ZIGZAG HEM

| | |
|----------------------|--------------------------|
| Fabric: | Firmly woven – 6" x 7" |
| Needle: | 90/14 Embroidery |
| Thread: | 30 wt. cotton embroidery |
| Presser Foot: | Reverse Pattern Foot #1 |

Owner's manual pg. ____

- Fold a 2" hem to the wrong side of the fabric; press.
- Select the Triple Zigzag Stitch #10/red.
- Adjust stitch length and width as desired.
- From the right side of the fabric, stitch the hem in place, sewing about 1½" from the fold.
- From the wrong side, trim the excess fabric close to the stitches.
- Press and mount the sample.

DOUBLE NEEDLE HEM

| | |
|----------------------|----------------------------|
| Fabric: | Cotton interlock – 6" x 7" |
| Needle: | Double 3.0/80 |
| Thread: | All-purpose, 2 colors |
| Presser Foot: | Reverse Pattern Foot #1 |

Owner's manual pg.____

- Turn up a 2" hem along one of the 6" edges and press.
- Insert a 3.0/80 double needle.
- Thread the needles with two different colors of thread.
- Place the folded edge of the fabric along the 1" guideline on the right side of the stitch plate.
- Select stitch #1/green; sew half of the hem.
 - Note: To be sure the needles will not strike the foot, turn the handwheel to "walk" the machine through the first stitch. Narrow the width as needed to avoid breaking needles.*
- Select stitch #3/green or experiment with similar stitches; stitch the remainder of the seam.
- Trim excess fabric from the wrong side of the hem.
- Check *Feet-ures*, Unit A for detailed information on working with Double and Triple needles.
 - Note: This is a good stitch to use when hemming T-shirts and pajamas. You can use other stitches with a double needle for other types of fabrics.*
- Press and mount the sample.

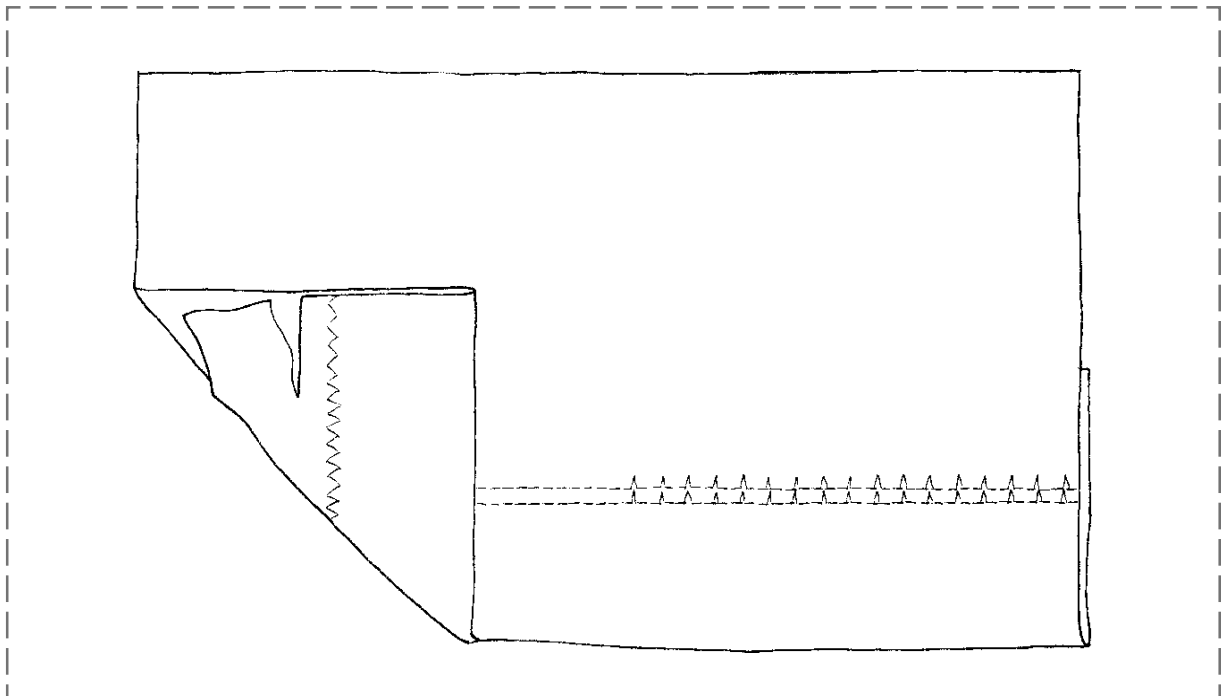

JEANS HEM

| | |
|----------------------|------------------------------------|
| Fabric: | Denim – 5" x 7" |
| Needle: | 100/16 or 110/18 Jeans |
| Thread: | All-purpose |
| Presser Foot: | Jeans Foot #8 (optional accessory) |

Note: Specially designed to sew over heavy seams and fabrics, the Jeans Foot #8 guides the needle through heavy thicknesses and helps to eliminate needle breakage. It is also effective for topstitching with buttonhole twist or cordonnet threads.

Owner's manual pg. ____

- Cut fabric in two pieces, 5" x 3½" each.
- Insert a Jeans needle and select stitch #1/green; adjust length to 3mm.
- Sew a 5/8" seam with right sides together.
- Press the seam to one side.
- Topstitch, using the edge of the foot along the seam as a guide, and stitching through the seam allowances.
- Turn up the lower edge twice, about 3/8" each time.
- Topstitch the hem in place, about 1/8" from the upper edge of the hem.
- Press and mount the sample.

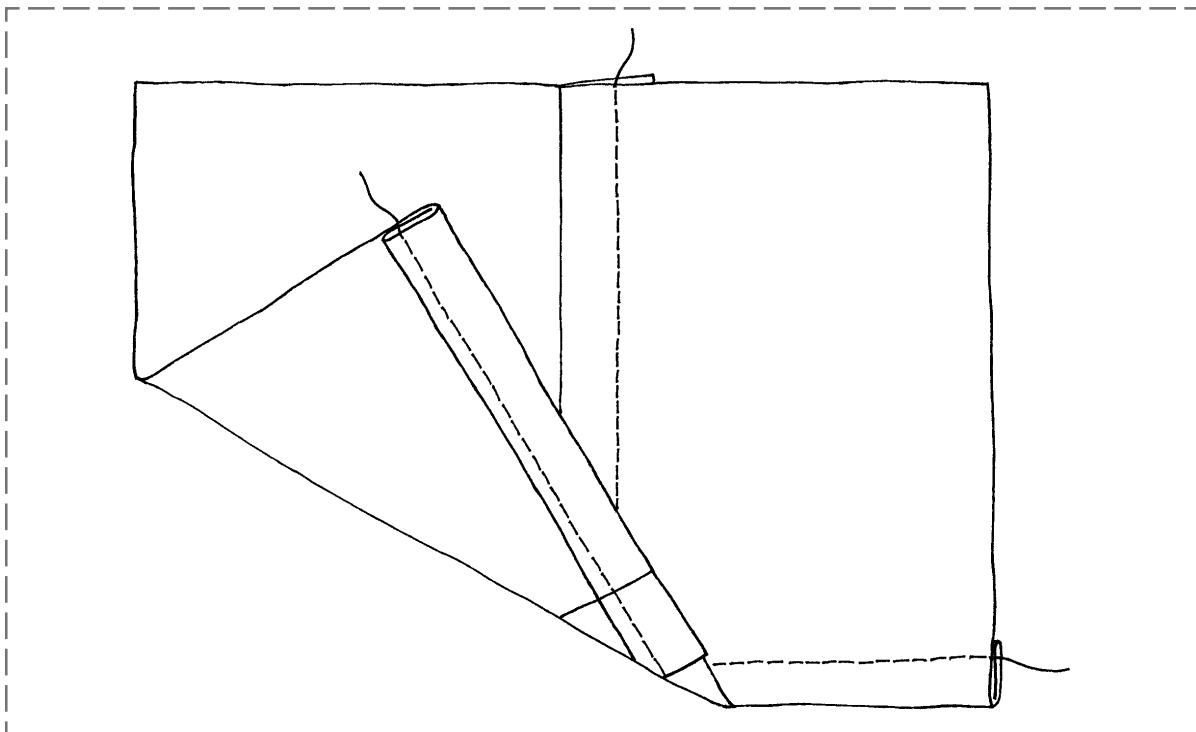

WISH LIST

Let's Start With The Basics

- Presser Feet and Attachments:
 - Overlock Foot #2
 - Embroidery Foot #6
 - Jeans Foot #8
 - Edgestitch Foot #10
 - Straight Stitch Foot #13
 - Cut and Sew Attachment #80
- Feet-ures*
- Double Needles
 - 2.0mm
 - 2.5mm
 - 3.0mm
- Jeans Needles
 - 90/14
 - 100/16
 - Double
- Stitch Witchery - $\frac{5}{8}$ " roll
- BERNINA® Ironing System
- Curved Hem Ruler
- 6" Sewing Gauge
- Seam Pressing Stick
- BERNINA® Cutting Mat
- BERNINA® 14" Ruler

MASTERING YOUR

BERNINA® *Electronic 1008*

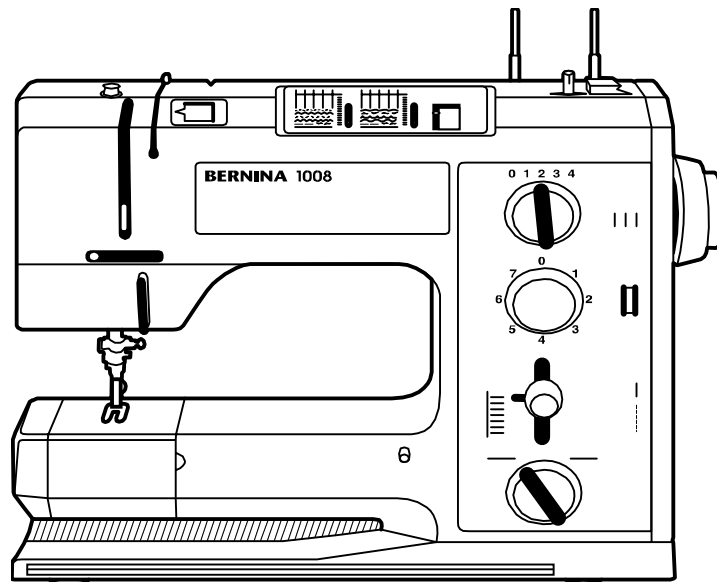

OWNER'S WORKBOOK

Section C On The Edge

SECTION C

On The Edge

Buttonholes

Owner's manual pg. _____

Feet-ures, Unit A

- Types and Uses
- Preparation
 - proper stabilizers
 - sometimes using two or more layers
 - proper adhesion of iron-on stabilizers
- Positioning:
 - marking
 - full bust can be beginning point
 - using spacing tape
 - using Simpflex
- Measuring the Button:
 - to determine length of buttonhole
- Grading Seams
 - using applique scissors
- Height Compensation Tool
 - keep foot level
- Tension Adjustments
- Testing:
 - always use same fabric, thread and stabilizer
- Cutting Open:
 - seam sealant
 - block and cutter
- Tricks:
 - wash-a-way stabilizer for high pile fabrics
 - Stitch Witchery® for loose wovens or knits
- Corded Buttonholes:
 - with gimp cord
 - with threads

Sewing Buttons On

Owner's manual page _____

Feet-ures, Unit D

- Universal Stitch
 - regular
 - decorative
 - snaps, hooks, and charms
 - tie a quilt













Edges

- Picot – *Feet-ures*, Unit D
- Shell
 - blindstitch – *Feet-ures*, Unit A
 - hemmer feet #68 or #69 – *Feet-ures*, Unit I
- Rolled and Whipped Edge – *Feet-ures*, Unit A
- Fine Edge – *Feet-ures*, Unit B
- Corded Edge – *Feet-ures*, Unit B
 - for tucks
 - for hems
- Designer Hem – *Feet-ures*, Unit B

Attaching Elastics

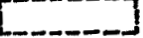
- Types
- Methods of applying
 - turn under
 - couching over
 - lingerie

BUTTONHOLES AND EYELETS TYPES AND USES

- X**  **STANDARD BUTTONHOLE**
Fine to medium weight fabrics. Blouses, shirts, trousers, bedlinens.
-  **HEIRLOOM BUTTONHOLE**
Fine to medium weight fabrics. Blouses, shirts, dresses, trousers. children's and baby clothes, doll clothes, heirloom work.
-  **STRETCH BUTTONHOLE**
All stretch fabrics made from cotton, wool, silk, and synthetic fibers.
-  **ROUND BUTTONHOLE WITH NORMAL BARTACK**
Medium to heavy weight fabrics of all types. Clothing, jackets, coats, rainwear.
-  **ROUND BUTTONHOLE WITH HORIZONTAL BARTACK**
Medium to heavy weight fabrics of all types. Clothing, jackets, coats, rainwear.
-  **KEYHOLE BUTTONHOLE WITH NORMAL BARTACK**
Heavy weight, non-stretch fabrics. Jackets, coats, trousers, leisure wear.
-  **KEYHOLE BUTTONHOLE WITH POINTED BARTACK**
Non-stretch firm fabric. Jackets, coats, leisure wear.
-  **KEYHOLE BUTTONHOLE WITH HORIZONTAL BARTACK**
Firm, non-stretch fabrics. jackets, coats, leisure wear.
-  **STRAIGHT STITCH BUTTONHOLE**
For prestitching buttonholes and pocket openings. For bound buttonholes & welt pockets.
-  **BUTTON SEW-ON PROGRAM**
For flat buttons with 2 and 4 holes. For sewing on snaps, hooks, and charms.
-  **NARROW ZIGZAG EYELET**
Opening for cords and narrow ribbons/bands, other decorative work.
-  **STRAIGHT STITCH EYELET**
Opening for cords and narrow ribbons/bands, other decorative work.

X available on the Electronic 1008

BUTTONHOLE FEET

A number of buttonhole feet are available for BERNINA® sewing machines. The descriptions below will help differentiate between the various feet.

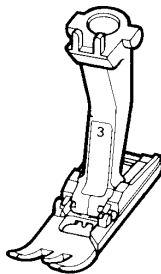

BUTTONHOLE FOOT #3

The standard 5mm buttonhole foot.
Works with any BERNINA® sewing machine

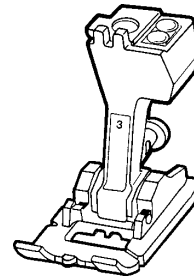

BUTTONHOLE FOOT #3C

The standard 9mm buttonhole foot.
“C” indicates a “coded” foot, with a light sensor that allows 9mm wide stitching.
Works with models 1630 and *artista* 180.

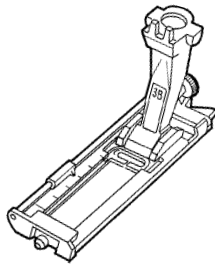

BUTTONHOLE FOOT WITH SLIDE #3B

A 5mm foot with a movable slide indicating buttonhole length, making it easy to stitch a series of identical buttonholes.
Works with any BERNINA® sewing machine.

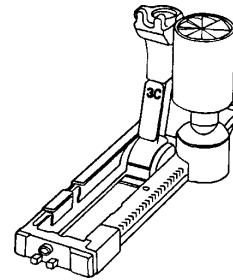

AUTOMATIC BUTTONHOLE FOOT #3C

The automatic buttonhole foot for machines with a 9mm feed system, indicated by the letter “C”.
Works with models 1630 and *artista* 180.

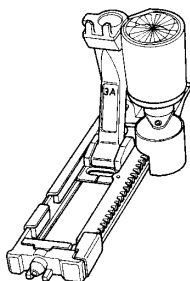

AUTOMATIC BUTTONHOLE FOOT #3A

Automatic foot for machines with a 5mm and 9mm feed system. “A” indicates an “automatic” foot, with a light sensor for counting stitches.
Works with models 1130-1530 and 150-170QPE.

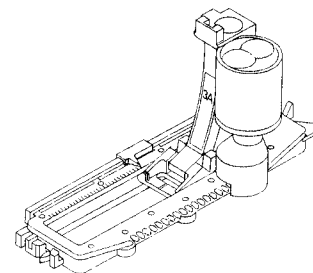

AUTOMATIC BUTTONHOLE FOOT WITH SLIDE #3A

Combines the handy slide measuring system of Buttonhole Foot #3B with the electronic sensor of the older Automatic Buttonhole Feet #3A and #3C.
Works with models 135 PE/145 and 150-180.

STABILIZERS

Tear-Away Stabilizer: The most commonly used type of stabilizer, designed to provide temporary support of stitching. Placed on the wrong side of the project and carefully pulled away once stitching is complete. Available in three weights – heavy, medium, and light. Multiple lightweight layers may be preferable to one heavy layer, as they are easier to remove.

Cut-Away Stabilizer: The most widely used stabilizer in the commercial market. Does not break down under dense stitching, due to the high fiber – rather than paper – content. Excess stabilizer is trimmed away after stitching (leave approximately ¼” of stabilizer around the edges).

Web/Poly-Mesh Type Stabilizer: A specially formulated cut-away stabilizer developed for use behind lightweight or light-colored fabrics.

Water-Soluble Stabilizer: Used for backing and topping, in single or multiple layers. Available in two weights. Excellent for decorative stitching and cutwork as there are no remnants of stabilizer left after removal (it dissolves). As a topping, it keeps stitches from being lost in heavily napped fabrics such as velvet and corduroy.

Knit Fusible Interfacing: A very lightweight, flexible interfacing sometimes used as a stabilizer, it gives permanent support (as an underlining) to a fabric. Perfect for plackets, garment edges, under buttonholes, and anywhere extra body and stability are needed.

Woven Fusible Interfacing: This interfacing is sometimes used as a stabilizer and is generally cut on the bias to provide better drape. Gives a firmer hand or finish than knit or non-woven interfacings. Used for lapels, facings, and anywhere a great deal of extra body and stability are needed.

Iron-On Stabilizer: A non-woven product similar to paper. Perfect for knits, this tear-away stabilizer is temporarily bonded to the fabric, inhibiting the tendency of the material to stretch.

Heat Removable Stabilizer: Woven from strands of fiber that are burned away at a low temperature, heat removable stabilizers are perfect for heirloom stitchery.

Liquid/Spray Stabilizers: Wonderful for sheer fabrics from which all stabilizer must be removed after stitching, these products are painted or sprayed onto the fabric. Several light applications of spray stabilizer are preferable to one heavy application.

MANUAL BUTTONHOLES

| | |
|----------------------|-----------------------------|
| Fabric: | Heavy flannel, 6" x 6" |
| Stabilizer: | 1 piece, 3" x 6" |
| Needle: | 90/14 Embroidery |
| Thread: | 30 weight cotton embroidery |
| Presser Foot: | Standard Buttonhole Foot #3 |

Owner's manual pg. _____

- Fold one piece of fabric in half to 3" x 6". Press and insert the stabilizer.
- Draw a line 1½" from the fold along the 6" length.
- Mark two horizontal lines, running between the fold and the drawn line, spaced about 2" apart.
- Set the buttonhole knob at position #1.
- Adjust stitch length to satin (0.5).
- Position the foot over the first line and place the fold on the 5/8" line behind the presser foot.
- Sew the first side of the buttonhole.
- Stop at the drawn line *with the needle out of the fabric*.
- Turn the buttonhole knob to position #2.
- Sew back to the beginning of the first bead and stop.
- Turn the buttonhole knob to position #3.
- Sew the bartack and the right bead; stop and touch quick reverse.
- Sew the top bar tack. The fourth position sews the second bead, the fifth position sews the bottom bartack and the sixth position sews the securing stitches.
- Sew a second buttonhole on the second line.
- Cut one buttonhole open.
- Trim and mount the sample.

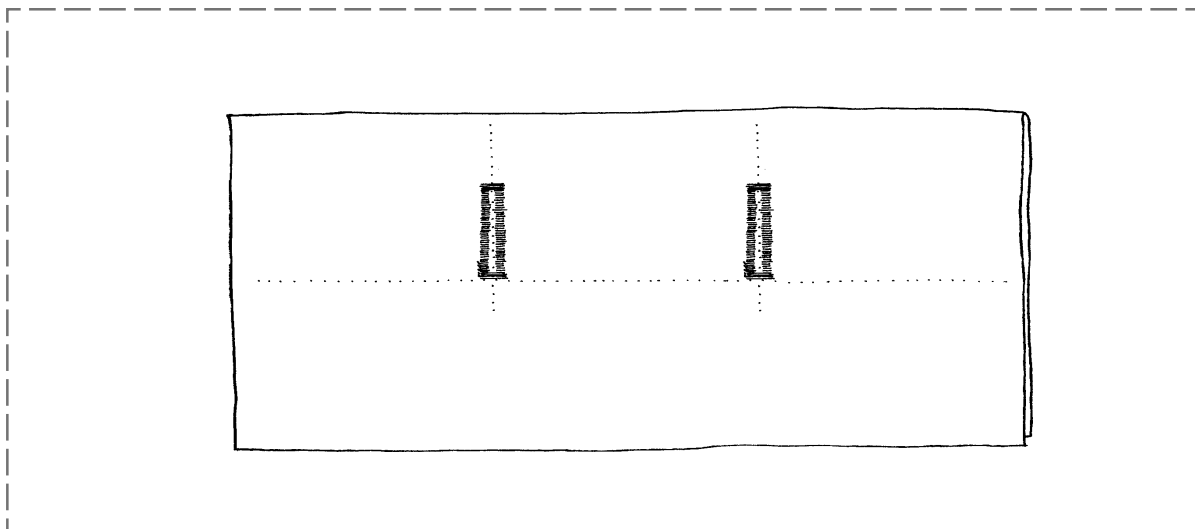

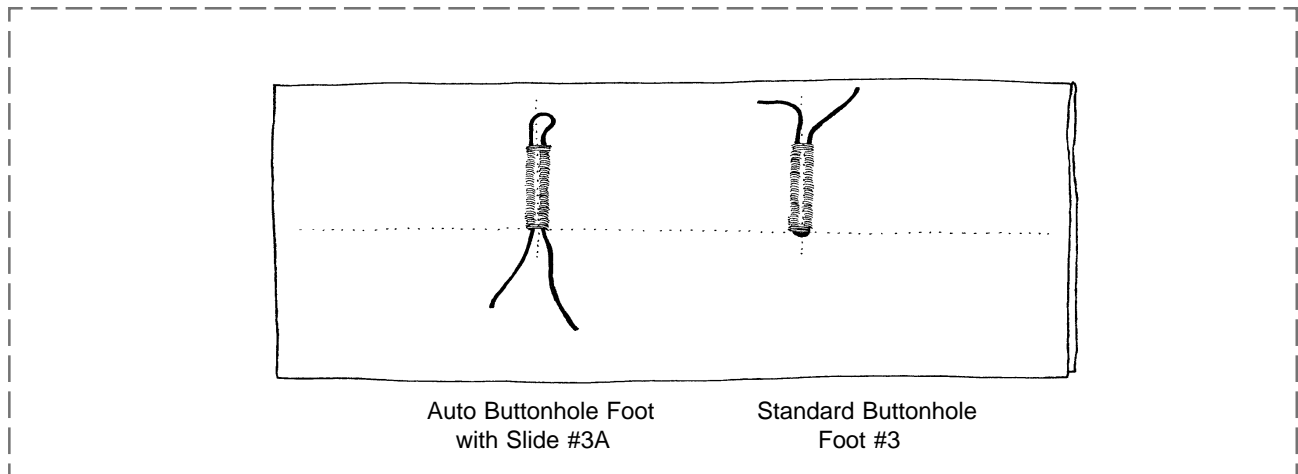

CORDED BUTTONHOLES

| | |
|----------------------|--|
| Fabric: | Heavy flannel, 6" x 6" Two 10" lengths of gimp cord |
| Stabilizer: | 1 piece, 3" x 6" |
| Needle: | 90/14 Embroidery |
| Thread: | 30 weight cotton embroidery |
| Presser Foot: | Standard Buttonhole Foot #3 and Buttonhole Foot with Slide #3B (optional) |

Owner's manual pg. ____

- Fold the fabric in half to 3" x 6". Press and insert the stabilizer.
- Mark a line 1½" from the fold and running the length of the fabric.
- Mark two horizontal lines between the fold and the line, spaced about 2" apart.
- Set the buttonhole knob at position #1.
- Place the fold so it is on the 5/8" line behind the presser foot.
- Lower the needle into the fabric on the first line.
- Fold one piece of cord in half; place loop around prong of the Buttonhole Foot with Slide #3B.
Note: The cord strengthens the buttonhole on wovens and prevents it from stretching on knits. The thickness of the cord depends on the fabric to be sewn. Suitable cords are perle cord #8, thick hand sewing thread, gimp cord, or crochet cotton.
- Sew the buttonhole.
- Pull the loop of gimp cord snug and cut tails close to bartack.
Note: On knits, pull to back and tie a knot.
- Sew another corded buttonhole using the optional Buttonhole Foot #3 on the second line.
- The cord may come away from the prong of this foot. Therefore it is advisable to hold the loop of the gimp down lightly with the finger.
- Pull the cord ends to the back with a large hand sewing needle and tie.
- Trim and mount sample.

BUTTON SEW-ON STITCH

| | |
|----------------------|---|
| Fabric: | Heavy flannel, 6" x 6" |
| Stabilizer: | 1 piece, 3" x 6" |
| Needle: | 90/14 Embroidery |
| Thread: | 30 weight cotton embroidery |
| Presser Foot: | Button Sew-On Foot #18 (optional accessory) |

Owner's manual pg. ____

- Select Universal Stitch #4/green; adjust width as needed.
- Lower the feed dogs.
- Fold the fabric in half to 2" x 6"; press. Insert the stabilizer.

Notes: - You can sew buttons on to stay!

- *A low shank can be made for dresses and blouses or a high shank can be made for heavier fabrics such as coats and blazers.*
- *Use the Button Sew-On Foot #18 to sew on waistband closures, hook-and-eye fasteners, snaps, curtain rings, and charms.*

Technique #1

- Select Universal Stitch #4/green set up as above.
- Use a glue stick to position a button in place.
- Adjust the pin on Foot #18 to the highest position for a long shank.
- Check the distance between the holes of the button by turning the hand wheel.
- Adjust the stitch width if necessary.
- Hold the thread tails as you begin to sew.

Technique #2

- Using the lowest shank setting, attach a charm, a length of ribbon, and a hook-and-eye to the same fabric.
- Trim threads close and mount the sample.

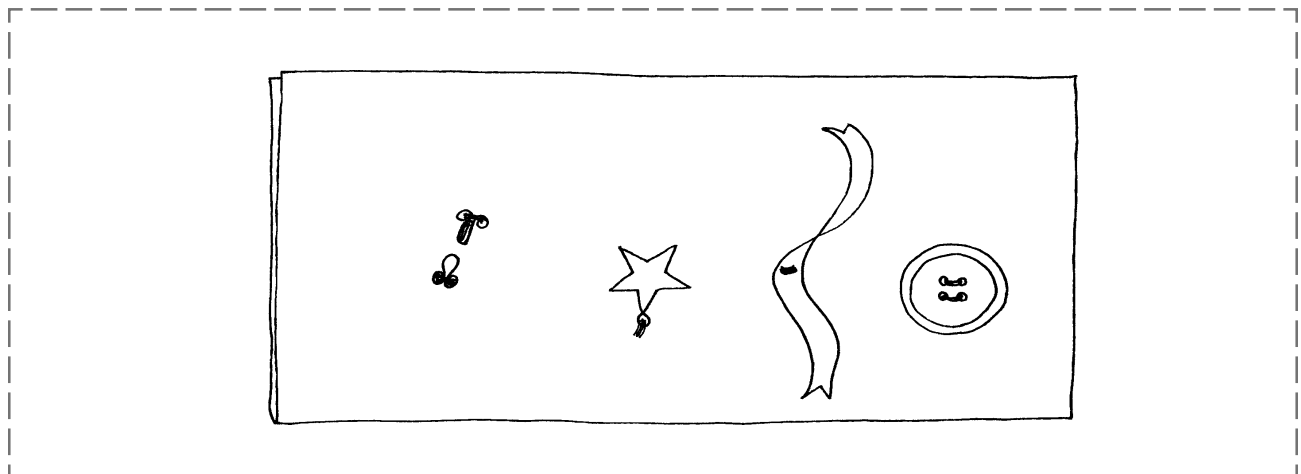

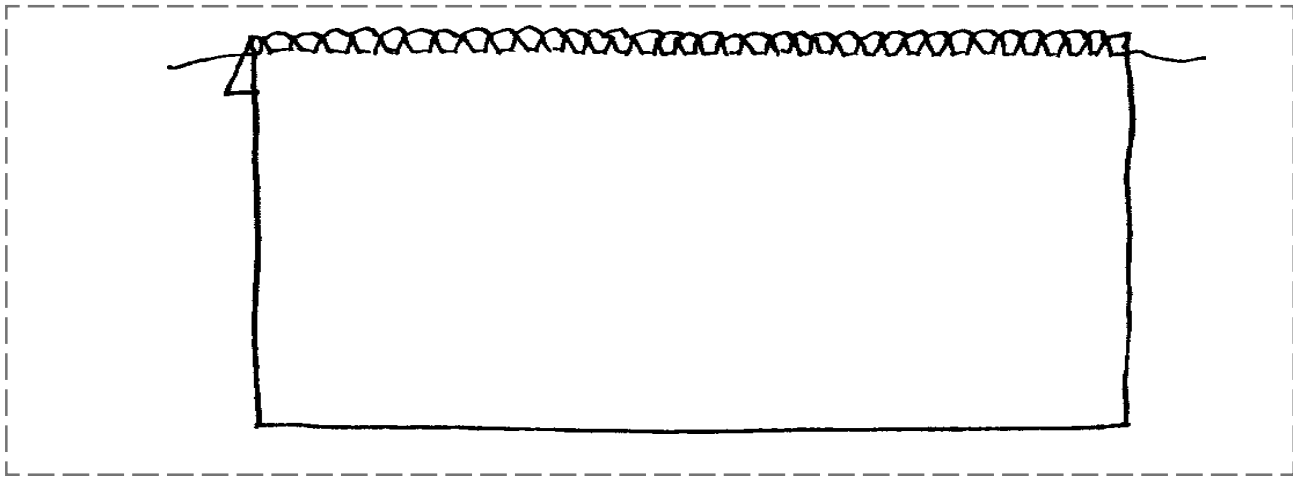

PICOT EDGE

| | |
|----------------------|---|
| Fabric: | Lightweight single knit cotton, 6" x 4" |
| Needle: | 80/12 Universal |
| Thread: | All-purpose sewing thread |
| Presser Foot: | Reverse Pattern Foot #1 |

Owner's manual pg. ____

- Select the Vari-Overlock Stitch #6/green - SW 4-5mm and SL 1.5mm.
- Fold under one 6" edge about ½" and press.
- Place fabric to the left and position it under the foot so that the stitch, when it swings to the right, will just pass over the folded edge.
- On knit fabrics the surplus can be trimmed from the wrong side close to the stitch.
- On woven fabrics it is advisable to first sew a row of small zigzag stitches about ¼" from where the picot edge will be. Then you will be able to trim close to these stitches after the picot has been stitched.
- Trim and mount the sample.

This stitch is suitable only for fine, soft fabrics and is ideal for lingerie and nightwear.

SHELL EDGE

| | |
|----------------------|---------------------------|
| Fabric: | Nylon tricot, 6" x 4" |
| Needle: | 80/12 Universal |
| Thread: | All-purpose sewing thread |
| Presser Foot: | Reverse Pattern Foot #1 |

Owner's manual pg. _____

- Select the Blindstitch #3/green -SW 2.5mm - 5mm and SL 1.5mm - 2mm. The longer the stitch length, the larger the shells.
- Fold under one 6" edge about ½" and press.
- Place fabric to the right and position it under the foot so that the stitch, when it swings to the left, will just pass over the folded edge.
- On knit fabrics the surplus can be trimmed from the wrong side close to the stitch.
- On woven fabrics it is advisable to first sew a row of small zigzag stitches about ¼" from where the shell edge will be. Then you will be able to trim close to these stitches after the edge is finished.
- Trim and mount the sample.

This stitch is suitable for fine, fabrics and is ideal for lingerie and nightwear.

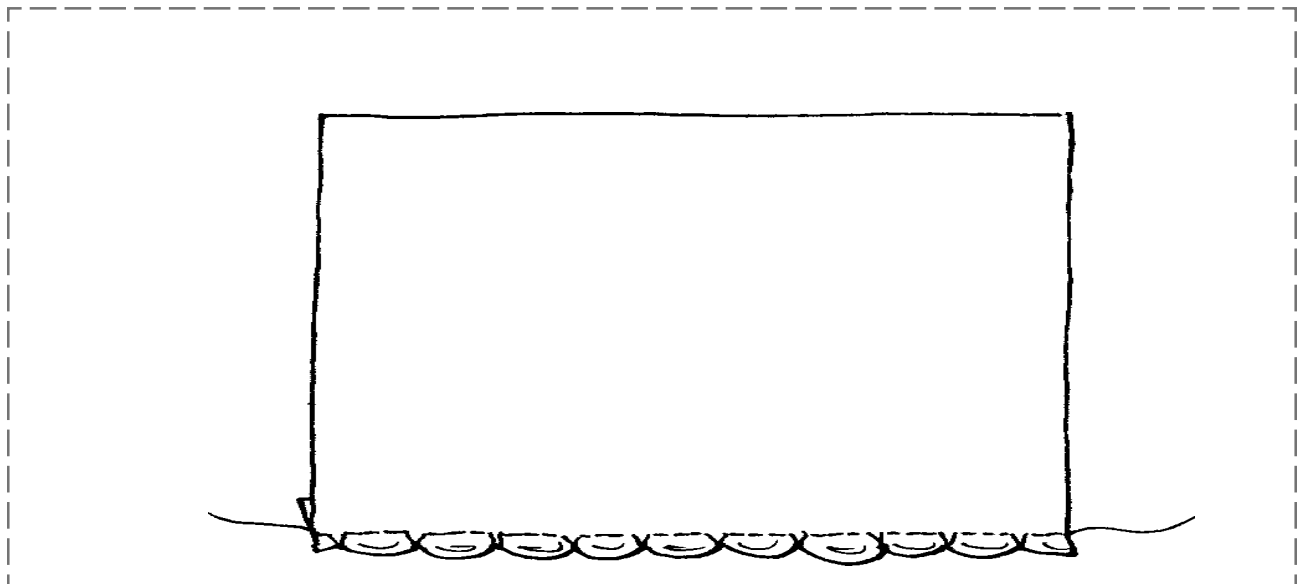

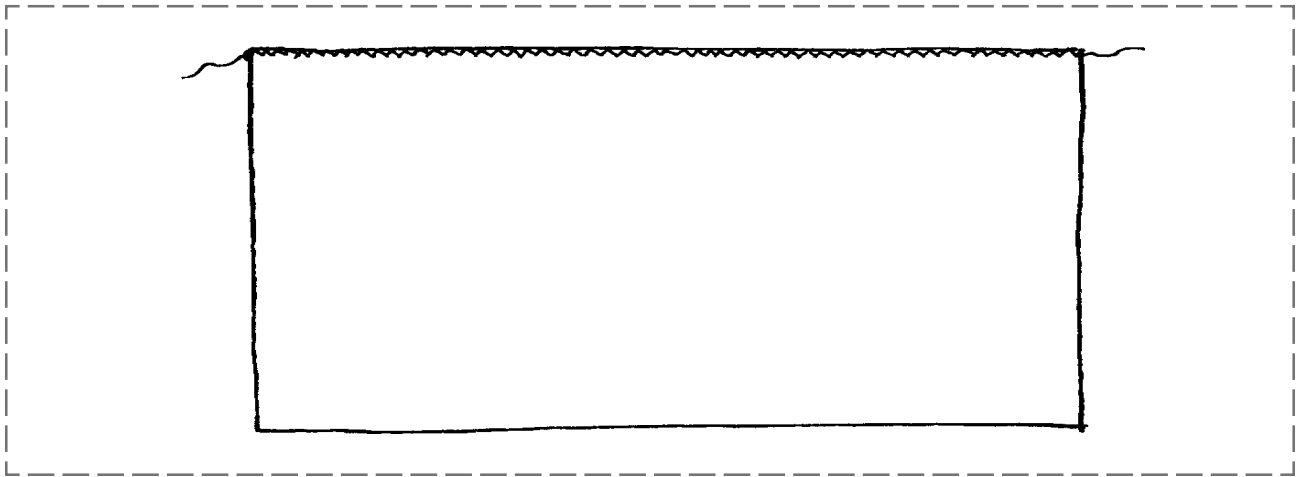

ROLLED AND WHIPPED EDGE

| | |
|----------------------|-----------------------------|
| Fabric: | Lightweight cotton, 6" x 4" |
| Needle: | 80/12 Universal |
| Thread: | All-purpose sewing thread |
| Presser Foot: | Buttonhole Foot #3 |

Owner's manual pg. ____

- Clean one 6" edge of "whiskers"
- Select the Zigzag Stitch #2/green - SW 2.5 and SL 1 or less.
- Select the left needle position.
- Loosen the top tension if necessary.
- Place cut edge of fabric between the center and right toes of the presser foot and sew.

Notes:

- *The left swing of the needle should be in the fabric, while the right swing falls off of the right edge of the fabric.*
 - *As the needle swings left, it should roll the fabric into a tiny rolled edge.*
 - *The finer the fabric, the finer the needle and thread used.*
- Trim and mount the sample.

This edge finish is used on a single thickness of fine lightweight fabrics. It is also use as a seam finish or as an edge on ruffles, hems etc.

FINE EDGE

| | |
|----------------------|--|
| Fabric: | Batiste, 6" x 4" |
| Needle: | 70/10 Universal |
| Thread: | 60 wt. needle and bobbin |
| Presser Foot: | Edgestitch Foot #10 (optional accessory) |

Owner's manual pg. ____

- Select the Zigzag Stitch #2/green - SW 2 and SL 1.
- Select the left needle position.
- Fold under ½" hem allowance on one 6" edge and press.
- Place the fabric right side upper most, to the left of the guide on the foot and sew the edge.
- When completed, trim away surplus fabric from the wrong side, close to the stitch.
- Mount the sample.

Note: Reverse Pattern Foot #1 can be used - settings as above but use center needle position.

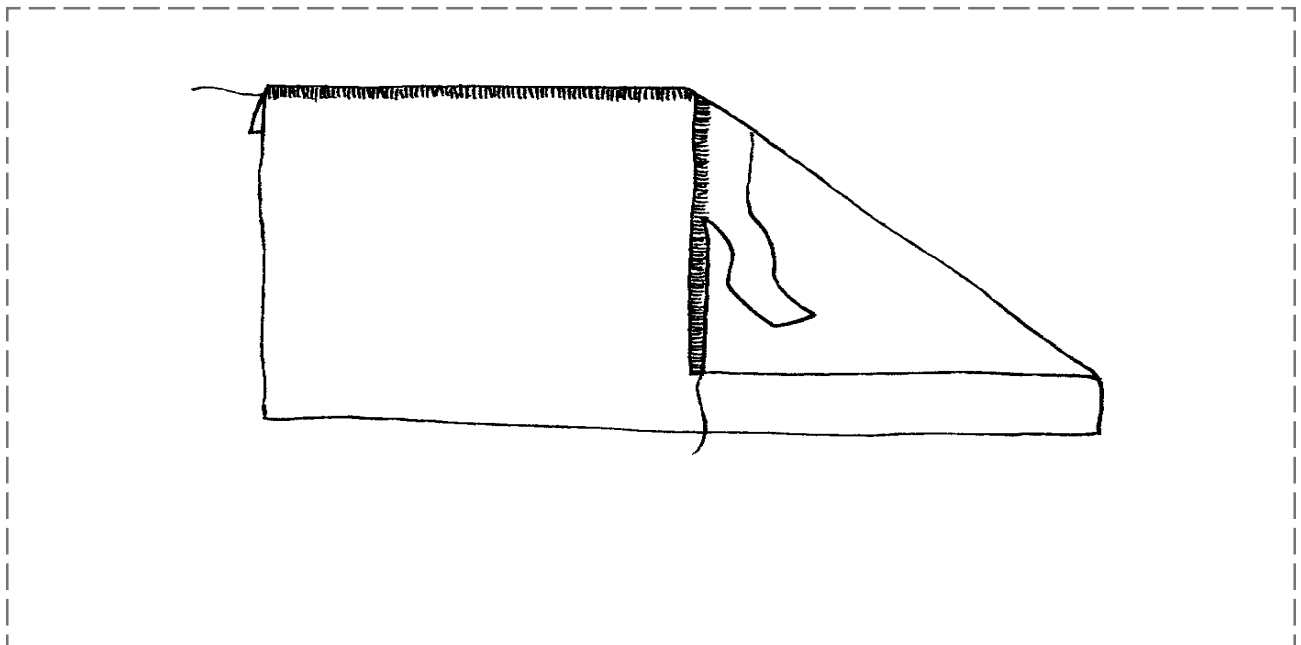

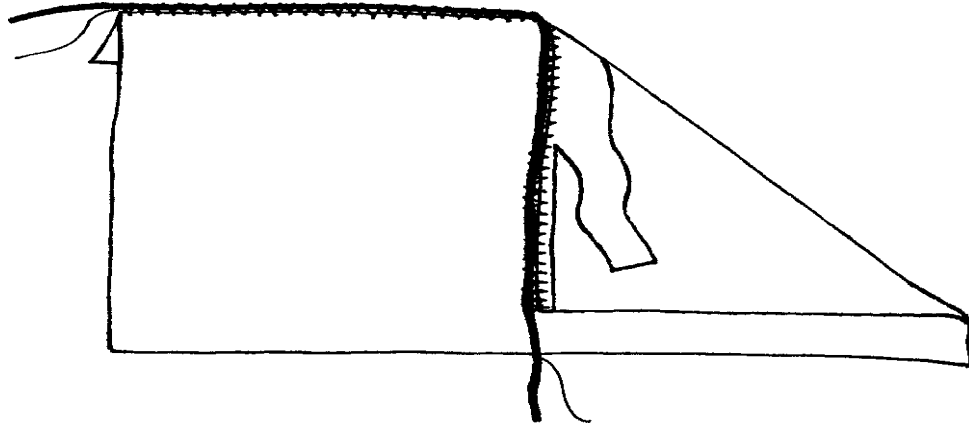

CORDED EDGE

| | |
|----------------------|---|
| Fabric: | Medium weight cotton, 6" x 4" Pearl Crown Rayon cord |
| Needle: | 80/12 Universal |
| Thread: | To match cord |
| Presser Foot: | Edgestitch Foot #10 (optional accessory) |

Owner's manual pg. _____

- Fold under a ½" hem allowance on one 6" edge and press.
- Place the folded edge, right side up, against the left side of the center blade.
- Select the Zigzag Stitch #2/green - SW 2 and SL 1 or adjust as needed.
- Adjust the needle position so the stitch falls on the folded edge.
- The right swing of the needle should barely miss the edge of the fold, stitching in air.
- Sew 2 or 3 stitches and stop with the needle down.
- Raise the foot, insert the cord under the foot from the right, against the needle.
- Pull the cord up through the center slot of the foot and hold it against the left side of the guide.
- Continue stitching - the cord will feed into the zigzag stitch.
- Trim the excess fabric from the wrong side.
- Mount the sample.

Note: Cord can be a variety of types - Pearl Crown Rayon works well.

DESIGNER HEM

| | |
|----------------------|---|
| Fabric: | Medium weight cotton, 6" x 4" Pearl Crown Rayon cord |
| Needle: | 80/12 Sharp |
| Thread: | All-purpose sewing thread |
| Presser Foot: | Edgestitch Foot #10 (optional accessory) |

- Select the Straight Stitch #1/green.
- Select the left needle position.
- Turn the raw edge under $\frac{3}{8}$ " and press.
- Stitch with the fold against the left side of the guide on the presser foot.
- Trim away seam allowance as close to stitching as you can get.
- Turn the first folded edge under again tightly and place the new fold against the left side of the guide on the foot.
- Stitch again from the wrong side of the fabric as in the first step.
- A successful hem will have two parallel lines of stitching on the wrong side of the hem and one showing on the right side.
- Trim and mount the sample.

*This is a very narrow two-step hem, easily sewn on straight or bias grains.
Works great on sheer fabric.*

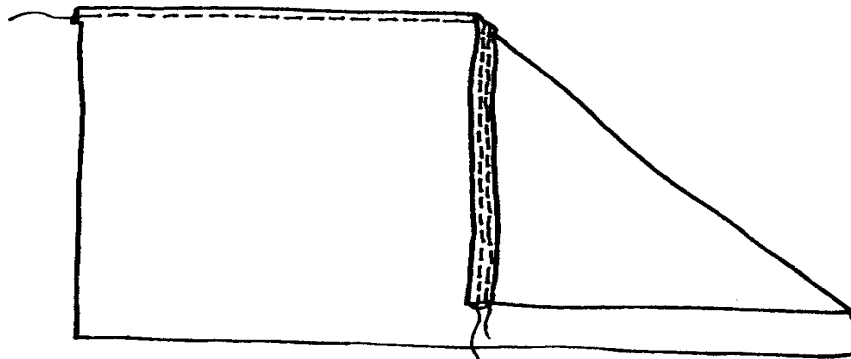

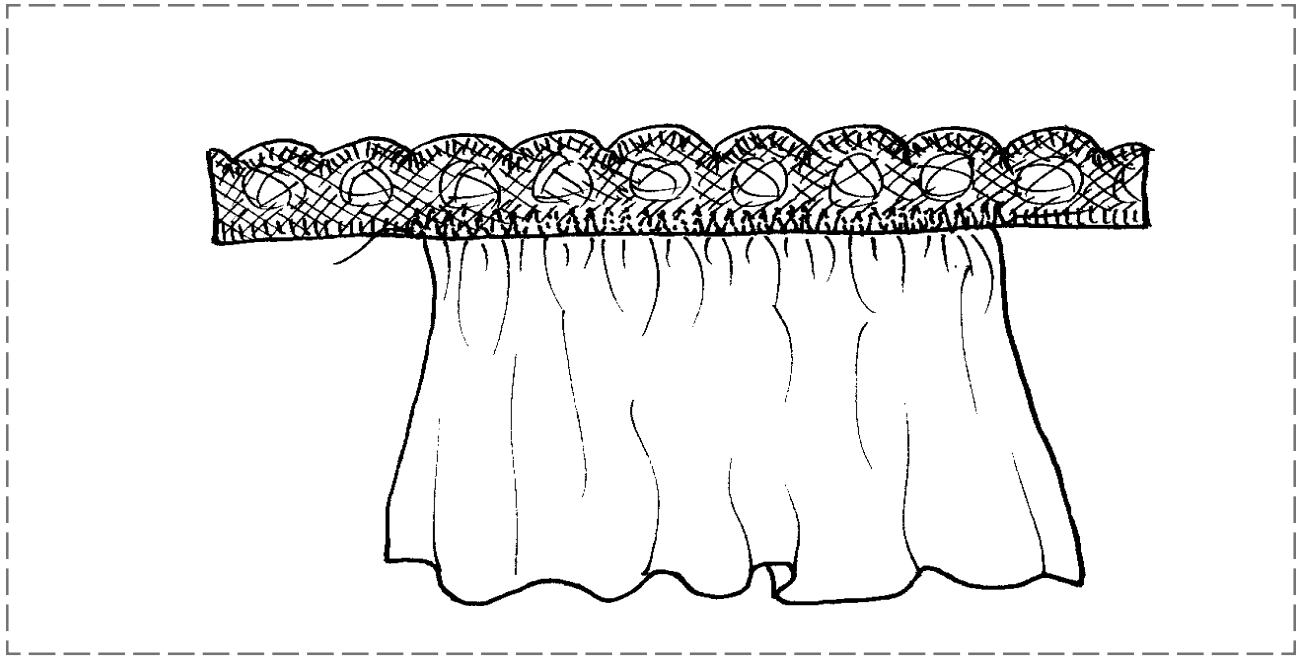

ATTACHING ELASTIC LACE

| | |
|----------------------|---|
| Fabric: | Nylon tricot, 6" x 4" 9" of elastic lace |
| Needle: | 80/12 Universal |
| Thread: | All-purpose sewing thread |
| Presser Foot: | Reverse Pattern Foot #1 |

- Select the Running Stitch #7/green.
- Adjust stitch length to 1mm.
- Position the elastic wrong side down on the right side of the tricot along one of the 6" edges.
- Leave a tail of elastic at the back of the presser foot for a "handle".
- Position the elastic so the stitching is at the bottom edge of the elastic lace.
- Stretch the elastic lace gently, as it is being sewn.
- After stitching, trim the surplus tricot from the wrong side of the elastic lace, close to the stitching.
- Mount the sample.

TURNED UNDER ELASTIC

| | |
|----------------------|---|
| Fabric: | Lycra - cotton or nylont, 6" x 5" 9" of cotton swimwear elastic, ½" wide |
| Needle: | 80/12 Universal |
| Thread: | All-purpose sewing thread |
| Presser Foot: | Reverse Pattern Foot #1 |

- Select Zigzag Stitch #2/green - SW 2mm and SL 2mm.
- Position the elastic on the wrong side of the fabric, along one 6" edge.
- Allow a 2" tail of elastic to extend beyond the fabric.
- Using the tail of elastic at the back of the presser foot for a "handle", stretch the elastic a bit to simulate the leg of an exercise leotard or swimsuit.

Note: This is the same procedure used to do a turned waistband, using wider elastic.

- Sew the elastic to the fabric keeping the edge of the elastic and the edge of the fabric together.
- If stopping midway, place the needle down to hold the elastic and fabric in place.
- Fold the elastic to the wrong side and overstitch the elastic from the right side using Running Stitch #7/green with a length of 1mm.
- Adjust stitch length if elastic stretches out as it is sewn.

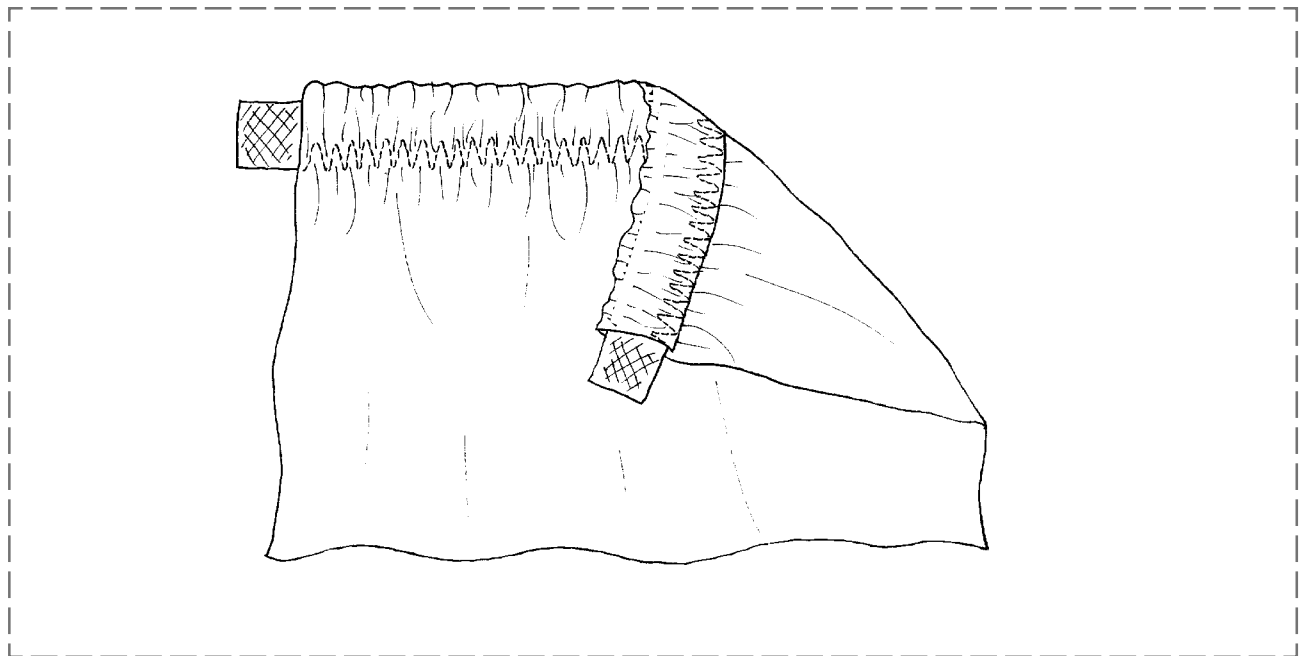

WISH LIST On The Edge

- Presser Feet:
 - Edgestitch Foot #10
 - Embroidery Foot #6
 - Buttonhole Foot with Slide #3B
 - Button Sew-on Foot #18
- Feet-ures*
- Gimp or Pearl Crown Rayon
- Stitch Witchery - roll
- Water-soluble stabilizer
- Buttonhole Space Tape
- Buttonhole Placement Gauge - Simpflex ruler
- ½" Drafting Tape
- Marking Pens/Pencils
- Applique Scissors - for grading seams
- Height Compensation Tool
- Seam Sealent
- Glue Stick
- Buttonhole Cutter and Block Set
- Double Needles
- Cotton elastics
- Accessory Box

MASTERING YOUR

BERNINA® *Electronic 1008*

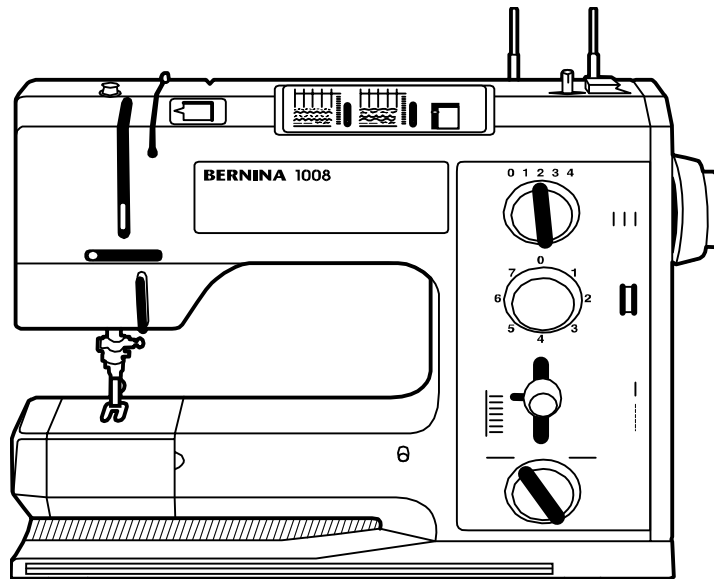

OWNER'S WORKBOOK

Section D

Gather It Up and Tuck It Down

SECTION D

GATHER IT UP AND TUCK IT DOWN

Gathering

- Gathering With A Basting Stitch
 - Lengthen stitch all the way
 - Tighten top tension for easier removal
- Gathering Over A Single Cord
 - Refer to *Feet-ures*, Unit B
 - Embroidery Foot #6 with stitch #2
- Elastic Thread In Bobbin Case
 - Refer to *Feet-ures*, Unit H
 - Use Black Latch bobbin case
- Narrow Casing Elastic
 - Refer to *Feet-ures*, Unit A
 - Open Embroidery Foot #20 with stitch #2
- Gathering Foot #16
 - refer to *Feet-ures*, Unit D
 - gathering a single layer
 - gathering to a flat piece
 - short stitch length for easing
- Ruffler Attachment #86
 - refer to *Feet-ures*, Unit J

Tucks

- Pintuck Feet and Double Needles
 - refer to *Feet-ures*, Unit F
 - which feet go with which needle
 - how to thread a double needle
 - how to use grooves in feet
- Corded Pintucks
 - refer to *Feet-ures*, Unit A
 - straight tucks
 - gimp hole
 - turning corners
- Pleats vs Tucks
 - refer to *Feet-ures*, Unit C
 - Edgestitch Foot #10
 - Reverse Pattern Foot #1
- Large Tucks and Pleats
 - refer to *Feet-ures*, Unit D
 - Quilting/Seam Guide
 - Zipper Foot with Guide #14
 - Guide Bars with Rulers
 - Piecing Guide
- Decorative Tucks
 - refer to *Feet-ures*, Unit F
 - sewn with decorative stitches vs straight
 - corded edges
 - lace inserted

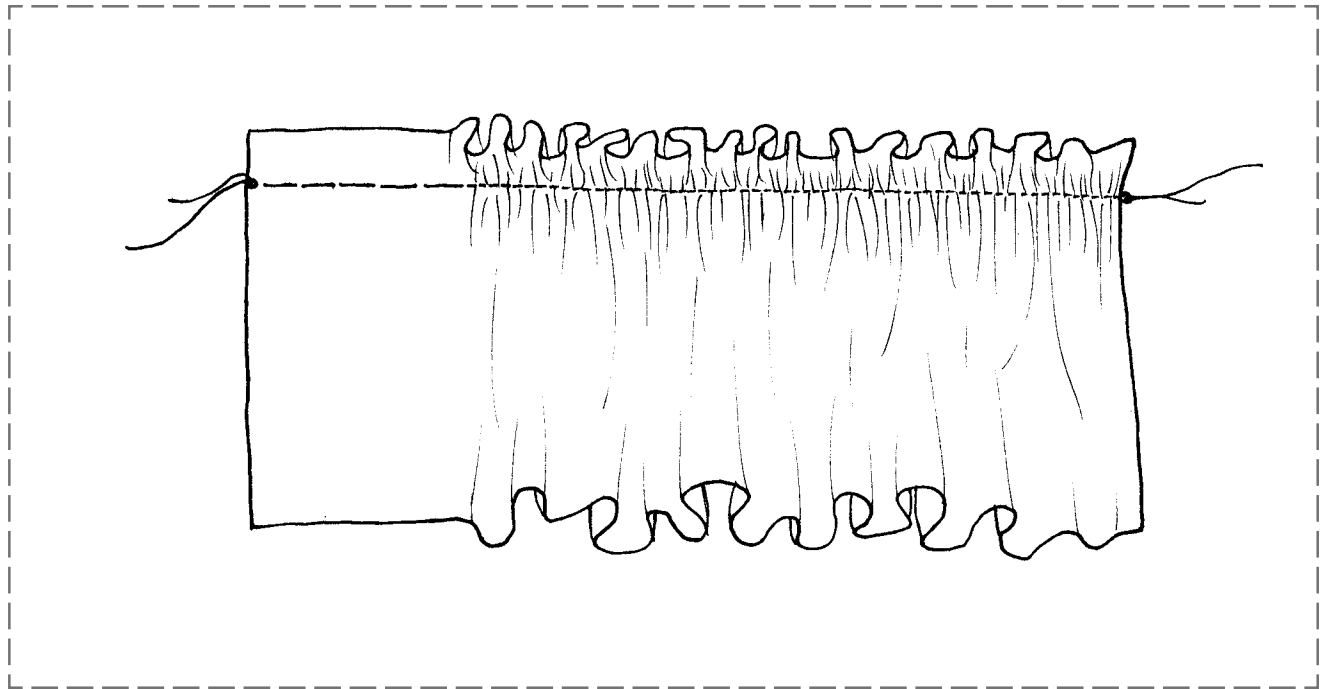

GATHERING WITH A BASTING STITCH

| | |
|----------------------|--------------------------------|
| Fabric: | Medium weight cotton, 12" x 4" |
| Needle: | 80/12 Universal |
| Thread: | All-purpose sewing |
| Presser Foot: | Reverse Pattern #1 |

- Trim all 4 edges of fabric piece with a wavy rotary cutter.
- Use all-purpose sewing thread top and bottom.
- Select Straight Stitch #1/green; adjust length to 5mm.
- Stitch $\frac{5}{8}$ " from one 12" edge.
- Tie the threads at the beginning to secure and gather the sample up to 6".

Notes:

- Use a fine darning thread; it is easier to remove after a seam has been sewn.
- To secure basting stitches, sew a few normal length straight stitches at the beginning and end of the seam.

GATHERING OVER A SINGLE CORD

| | |
|----------------------|---|
| Fabric: | Medium weight cotton, 12" x 4" 18" of cord |
| Needle: | 80/12 Universal |
| Thread: | All-purpose sewing |
| Presser Foot: | Embroidery Foot #6 (optional accessory) |

- Trim all four edges of sample fabric before beginning.
- Thread the cord through the hole in Foot #6, leaving a 2"-3" tail behind the foot.
- Select the Zigzag Stitch #2/green - SW 2.5 and SL 2-2.5..
- Stitch $\frac{5}{8}$ " from one 12" edge.
- Sew over the cord.
- Secure the cord at the beginning and then pull it to gather the sample to 6".

Notes:

- *Gathering over cord adds additional strength, eliminates thread breakage and allows better control of gathering.*
- *Drop the feed dog and sew a bartack at the beginning and end of cord for strength.*
- *Do not sew through cording.*

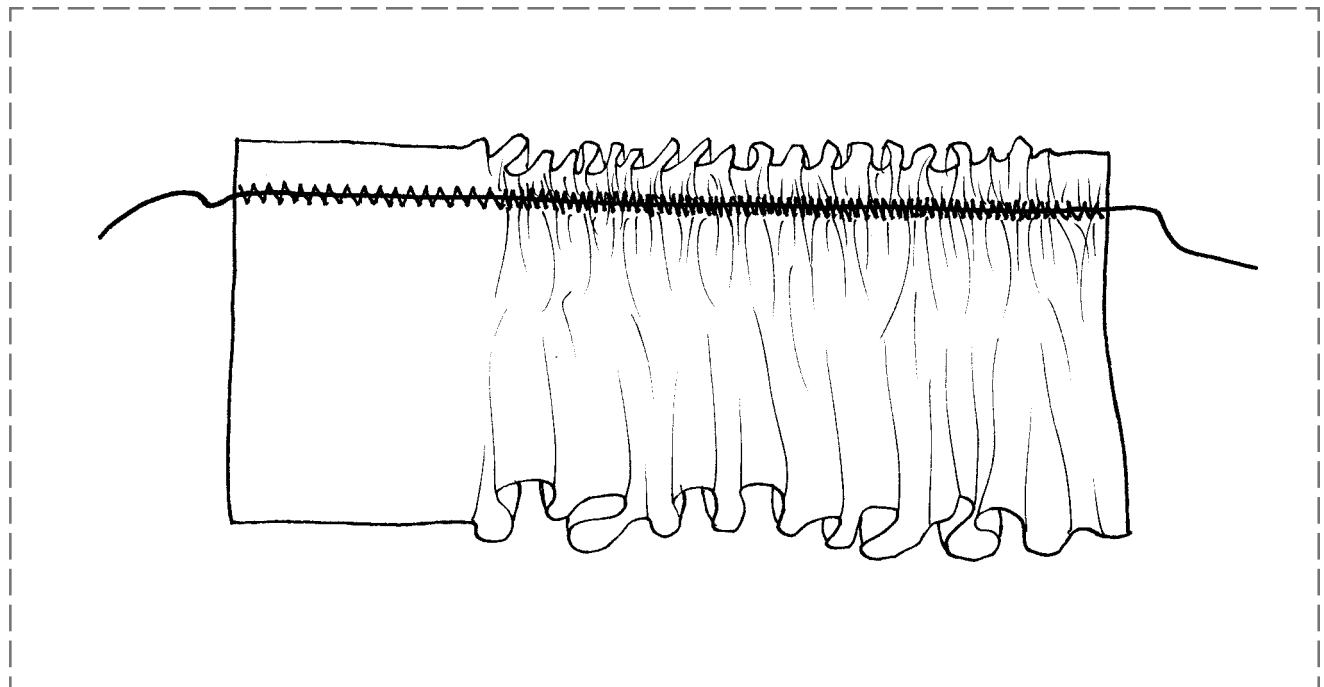

ELASTIC THREAD IN THE BOBBIN

| | |
|----------------------|---|
| Fabric: | Rayon Challis - 12" x 4" |
| Needle: | 80/12 Universal |
| Thread: | All-purpose sewing Elastic thread (bobbin) |
| Presser Foot: | Reverse Pattern Foot #1 |
| Other: | Black Latch Bobbin Case (optional) |

- Trim all four edges of the sample fabric before beginning.
- A Black Latch bobbin case is suggested.
- Wind elastic thread on the bobbin.
- Place in bobbin case and adjust tension if necessary.
- Select Straight Stitch #1/green - SL 4mm-5mm, center needle position, top tension 7-9.
- Draw guidelines on the fabric, spacing them evenly apart.
- Sew from the right side of the fabric.
- Keep rows flat as sewing.
- When finished, steam press the sample, holding the iron over the fabric with the elastic side up. Do not touch the iron to the fabric.
- Leave the fabric flat until dry.

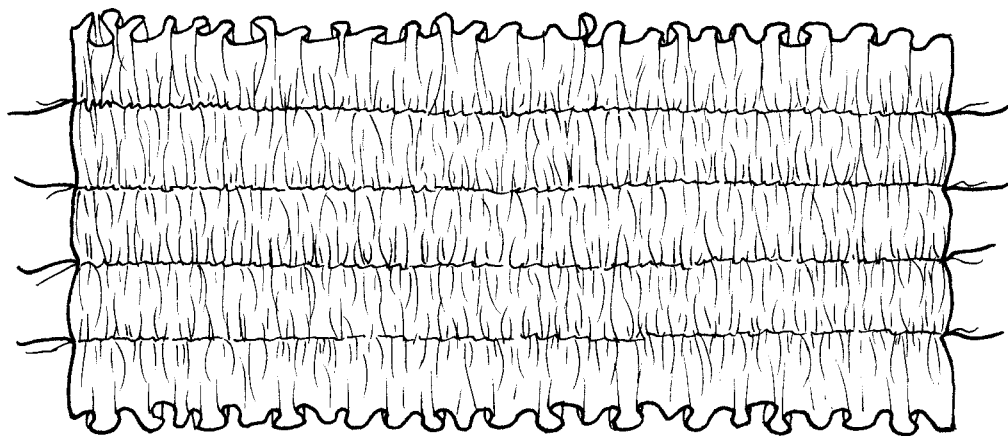

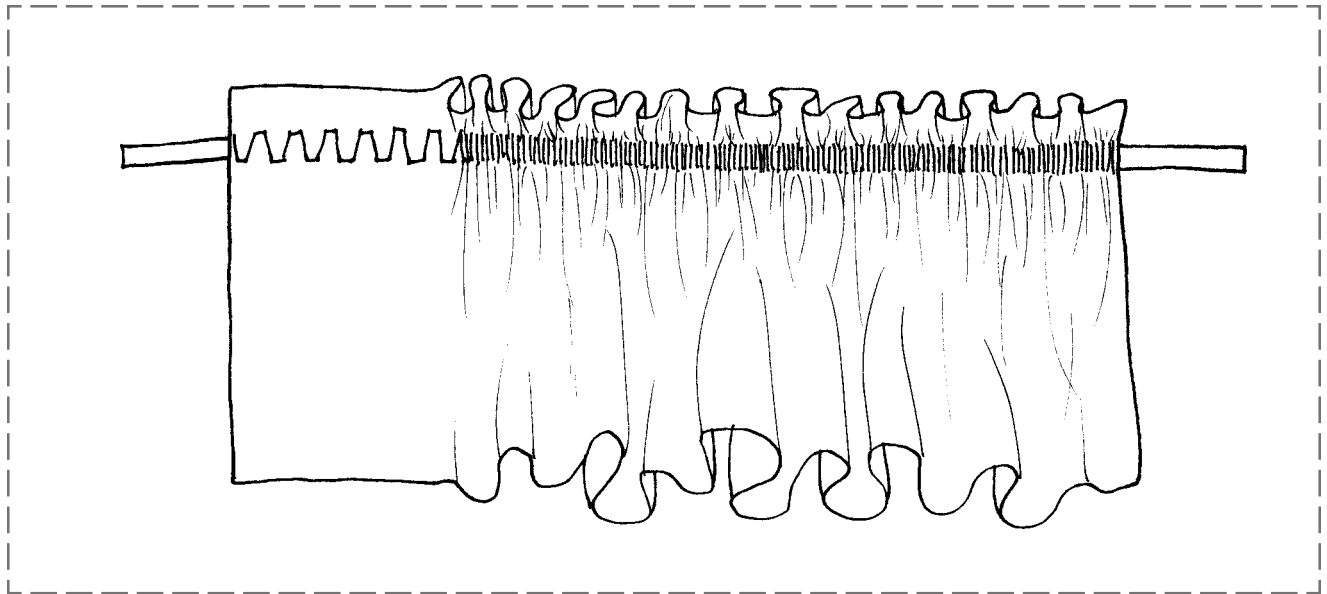

NARROW CASING ELASTIC

| | |
|----------------------|---|
| Fabric: | Medium weight cotton, 9" x 4" 12" of 1/8" or 1/4" cotton elastic |
| Needle: | 80/12 Universal |
| Thread: | All-purpose sewing |
| Presser Foot: | Reverse Pattern Foot #1 |

- Trim all four edges of the sample fabric before beginning.
- Select the Universal Stitch #4/green - adjust width to clear the elastic.
- Measure and mark the elastic for amount needed. Allow a 2" tail at both ends.
- Draw a line on the wrong side of the fabric where the elastic is to go (this could be the line on a pattern where a casing is suggested).
- Place the elastic over the line and under the foot and needle - sew a few straight stitches backward and forward to secure the elastic.
- Stretch the elastic gently to give the fullness desired.
- When you reach the other end, secure in the same manner as the beginning.
- Even out the gathers.

GATHERING FOOT #16

| | |
|----------------------|--|
| Fabric: | Medium weight cotton, 10" x 4" |
| Needle: | 80/12 Universal |
| Thread: | All-purpose sewing |
| Presser Foot: | Wide Gathering Foot #16 (optional accessory) |

- Trim all four edges of the sample fabric before beginning.
- Select the Straight Stitch #1/green - lengthen to 5mm.
- Place fabric to be gathered under the foot.
- Guide the fabric, keeping the raw edges even with the right edge of the foot, or use the seam lines on the throat plate.

Notes:

- *There are three things that effect the amount of gathers:*
 1. *Fabric Weight - The lighter weight the fabric, the easier to gather.*
 2. *Tension - Increased upper tension will increase the amount of gathering.*
 3. *Stitch Length - The longer the stitch length, the tighter the gathers.*
- *Use the basting stitch or the long stitch function to increase gathers in heavier weight fabrics such as woolens and corduroys.*

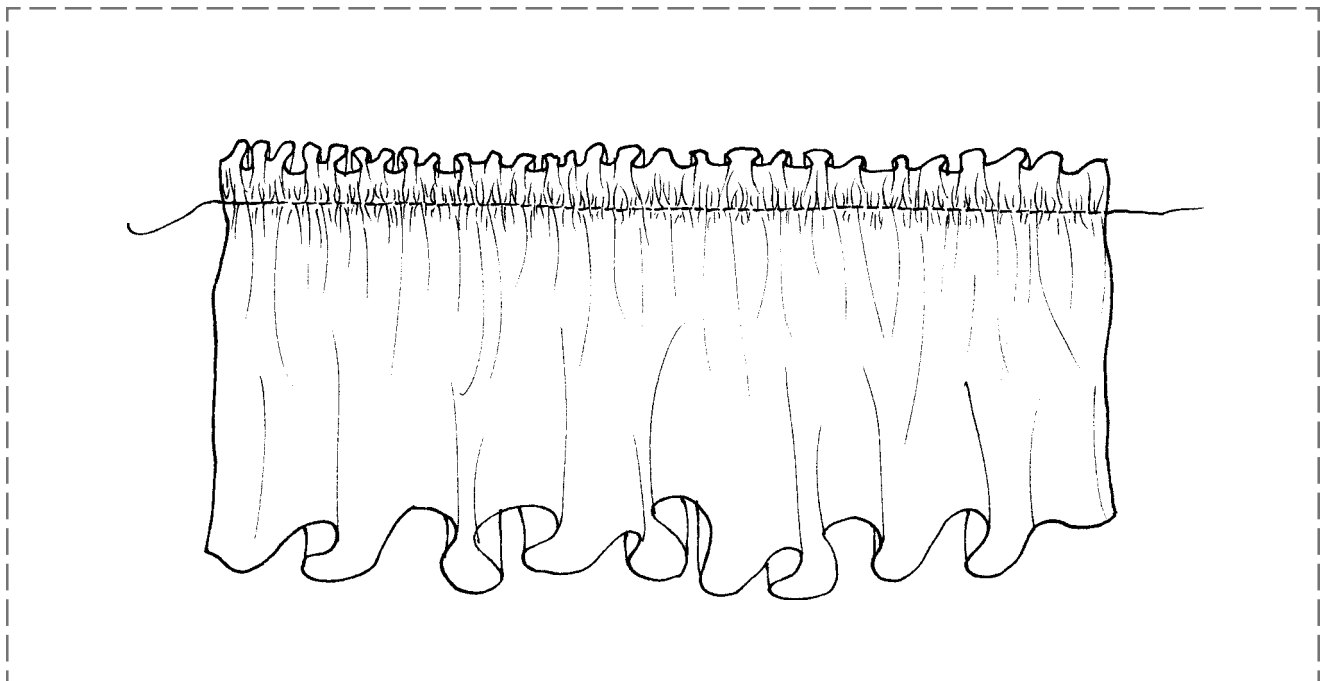

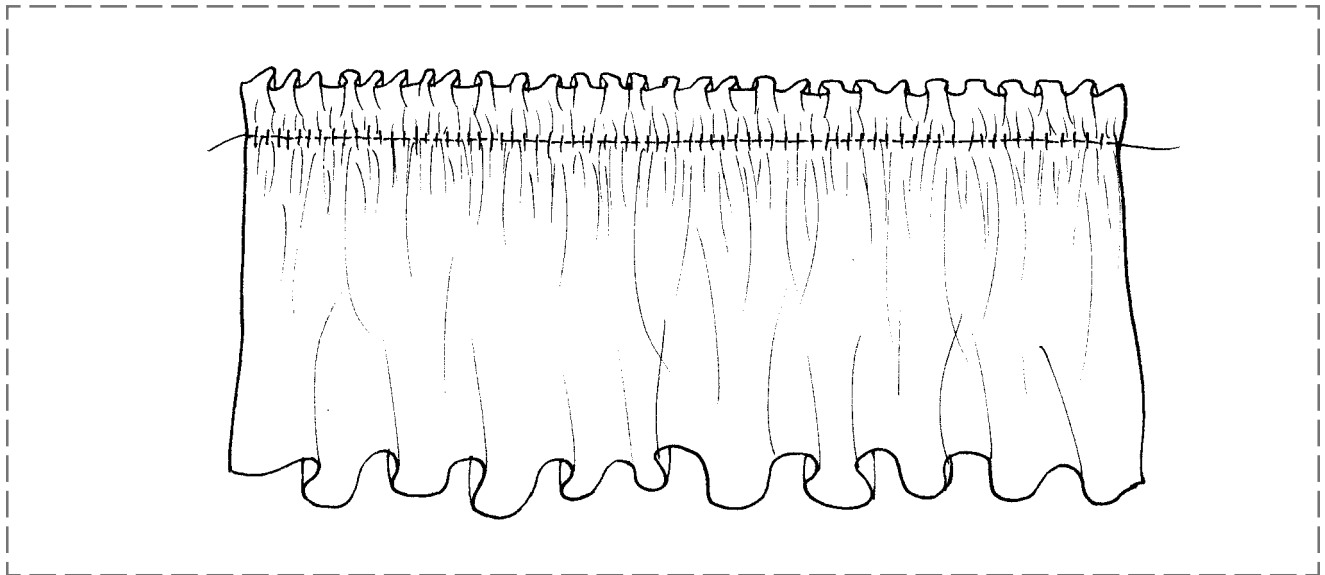

RUFFLER

| | |
|----------------------|---|
| Fabric: | Medium weight cotton, 12" x 4" |
| Needle: | 80/12 Universal |
| Thread: | All-purpose sewing |
| Presser Foot: | Ruffler Attachment #86 (optional accessory) |

- Trim fabric with wavy rotary cutter before sewing.
- Select the Straight Stitch #1/green - SL 1mm-5mm. The longer the stitch length, the deeper the pleat.
- Needle position is center.
- Set the adjustment lever on the attachment at 1.
- Place the fabric to be ruffled between the two blades, snugging it against the edge of the seam guide slot, making sure it is slightly beyond the needle.
- Lower the foot and begin sewing.
- If gathers are too deep, turn the adjusting screw counter clockwise; if too shallow, turn the screw clockwise.

Note: Loosening the needle tension to 3-4 will allow some subsequent adjustment of the fullness.

PINTUCKS AND DOUBLE NEEDLES

| | |
|----------------------|---|
| Fabric: | Lightweight cotton, 6" x 4", starched |
| Needle: | Double (size should correspond to foot) |
| Thread: | All-purpose sewing |
| Presser Foot: | Pintuck Foot #30, #31, #32, or #33 (optional accessories) |

- Select the desired presser foot and corresponding double needle:
 - Pintuck Foot #30 - 3 groove - 4mm needle
 - Pintuck Foot #31 - 5 groove - 3mm needle
 - Pintuck Foot #32 - 7 groove - 2mm needle
 - Pintuck Foot #33 - 9 groove - 1.6 needle
- Insert the double needle and thread with two different colors.
- Select the straight stitch #1/green - SL 1.75mm-2mm.
- Sew at a slower speed and test the movement of the needle. You want to be sure it doesn't hit the presser foot.
- Top tension can be tightened to create more dimension.
- Start sewing in one corner and meander across the fabric.
- Position the previously sewn tuck in the groove of the foot and sew 6 more rows evenly spaced across the fabric, as desired.
- Trim, press and mount the sample.

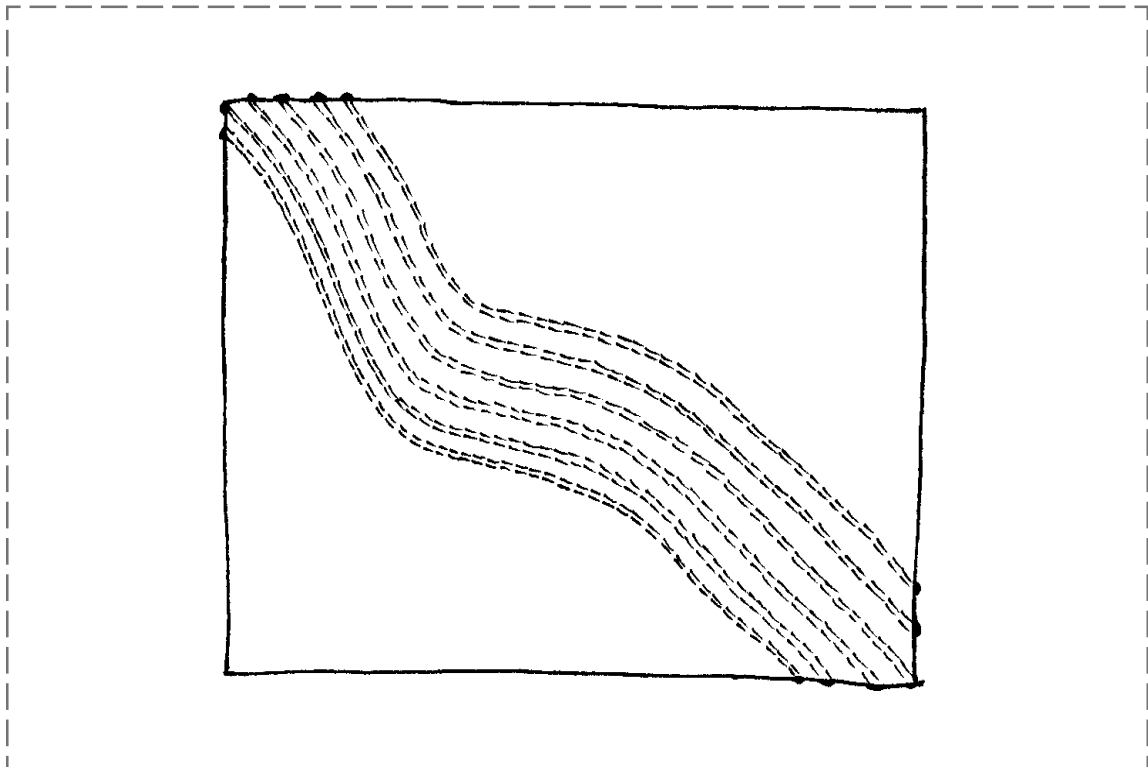

PLEATS vs TUCKS

| | |
|----------------------|---|
| Fabric: | Medium weight cotton, 8" x 5" |
| Needle: | 80/12 Universal |
| Thread: | All-Purpose |
| Presser Foot: | Reverse Pattern #1 Edgestitch #10 (optional accessory) |

Reverse Pattern Foot #1:

- Starting at the left edge and working across the 8" width, draw 4 lines for folding and pressing. The first 2 lines are 2" apart, second 2 lines are 1¼" apart.
Note: By placing the fold even with the right edge of the foot and placing the needle position all the way to the left to start, it is possible to get 9 different sizes pleats/tucks.
- Using Straight Stitch #1/green, sew the first tuck, on the first line, with needle position all the way to the left.
- Second tuck, on second line, with needle position all the way to the right.
- Each position makes about a 1mm difference.

Edgestitch Foot #10:

- Place the fold of the third pleat to the left of the center blade - right next to it.
- Move the needle position all the way to the left and sew.
- Position the fold of the last pleat in the same manner. Move the needle position to half left and sew.
- Very small tucks/pleats are possible with this foot.

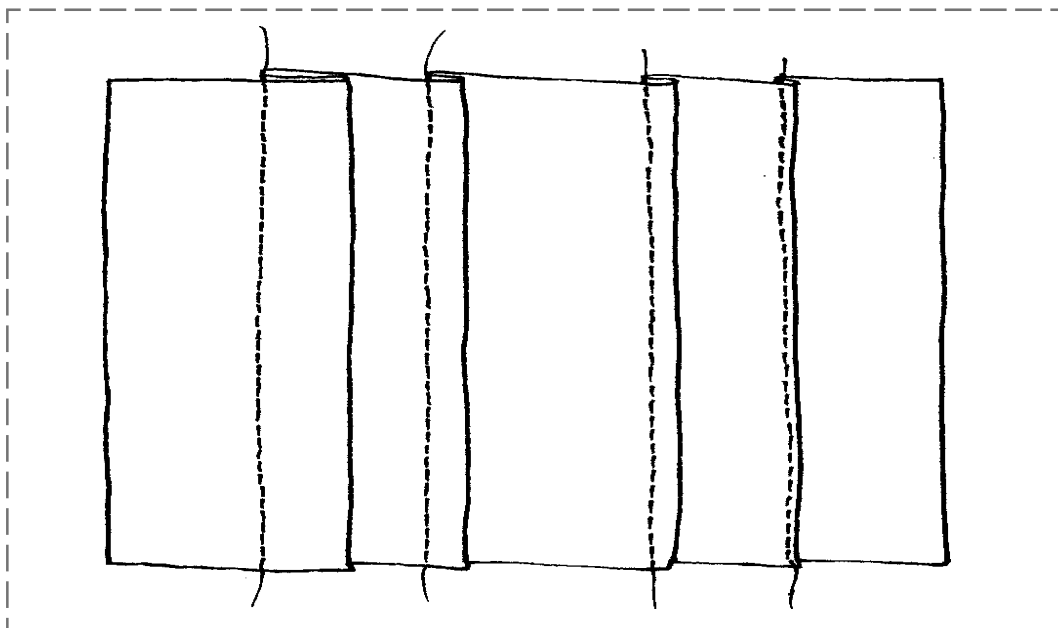

LARGE TUCKS/PLEATS

| | |
|----------------------|---|
| Fabric: | Medium weight cotton, 10" x 4" |
| Needle: | 80/12 Embroidery |
| Thread: | 30 wt. Cotton Embroidery |
| Presser Foot: | Zipper Foot with Guide #14 (optional accessory) |

Zipper foot #14 has a movable guide with 9 markings which ensure precise sewing of a variety of different size tucks.

- Select stitch #1/green - SL 2-5mm.
- Determine fold line of tuck. Fold on this line and press.
- Adjust the guide on the foot for the widest tuck possible.
- Place fabric under foot, positioning fold of tuck under the lip of the guide.
- Adjust Needle Position to correspond with notch on guide.
- Stitch tuck, allowing folded edge of fabric to feed into lip of guide.
- The optional Seam/Quilting Guide when attached to a one-piece foot, can create a pleat up to 2¼" wide. *Note: A left guide is available; also available is a set of guides with a ruler attached; they can be used to create pleats up to 4" wide.*
- Determine fold line of tuck. Fold on this line and press.
- Attach the guide to the foot and adjust for the widest tuck possible.
- Place fabric under foot, positioning the guide along the fold of the tuck.
- Adjust Needle Position to correspond with notch on guide.
- Stitch tuck, allowing the guide to ride on the folded edge of the fabric.

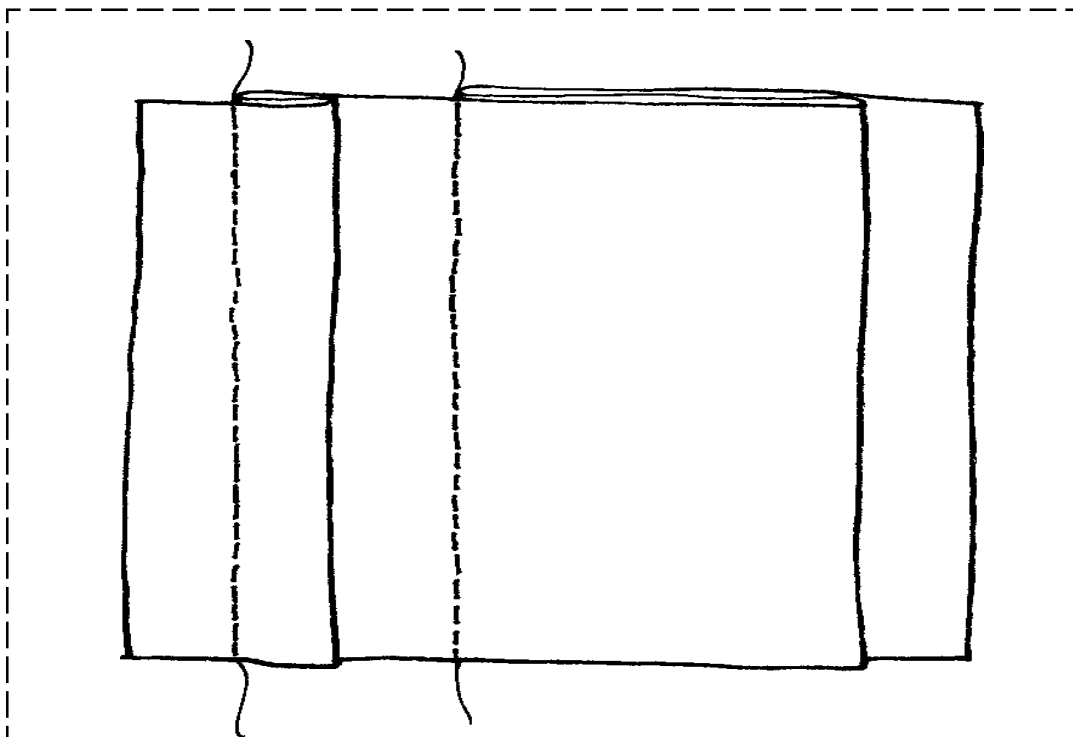

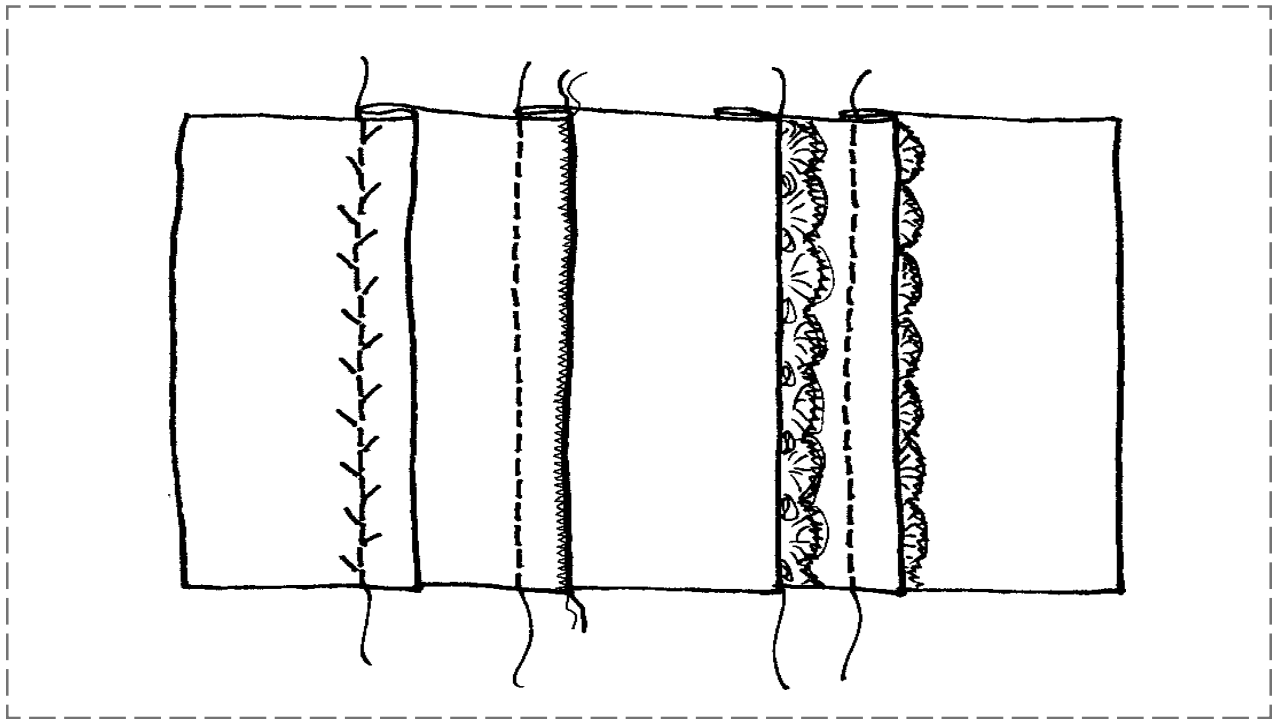

DECORATIVE TUCKS

| | |
|----------------------|--|
| Fabric: | Medium weight cotton, 8" x 4" |
| Needle: | 80/12 Embroidery |
| Thread: | 30 wt. Cotton Embroidery, Metallic, and matching cord |
| Presser Foot: | Depends on technique |

- Draw 4 lines about ¼" apart, across the width of the fabric.
- On the first line - create a tuck, about ¼", using a decorative stitch.
- On the second line - sew a ¼" tuck using a metallic thread with a straight stitch.
- Cord the edge of this tuck with a metallic cord as in Section C - Corded Edge.
- On the third line create an inverted tuck with lace inserted into it.
 - Place the edge of the lace against the drawn line, on the right side, and baste in place.
 - Fold the fabric over the lace and press.
 - Using Edgestitch Foot #10, place the pressed fold against the left side of the center blade - move needle position to the left enough to catch the lace; stitch to the left of the basting line.
 - Open out and press again.
- On the fourth line insert the lace with the tuck.
 - Fold wrong sides together and press the last tuck.
 - Place the edge of the lace in from the fold a scant ¼".
 - Using Foot #37 - the ¼" foot - stitch a tuck, catching the lace as you sew.
 - Press the tuck toward the lace.

WISH LIST

Gather It Up and Tuck It Down

- Presser Feet and Attachments:
 - Embroidery Foot #6
 - Edgestitch Foot #10
 - Zipper Foot With Guide #14
 - Wide Gathering Foot #16
 - Open Embroidery Foot #20
 - Pintuck Feet
 - #30 - 3 groove
 - #31 - 5 groove
 - #32 - 7 groove
 - #33 - 9 groove
 - Patchwork Foot #37
 - Ruffler Attachment #86
- Feet-ures
- Double Needles
 - 1.6mm
 - 2.0mm
 - 2.5mm
 - 3.0mm
 - 4.0mm
- Guide Bar Set with Rulers
- Elastic thread
- Gimp cord
- Extra Bobbin case
- Accessory Box
- GooGone
- Sewing Iron
- Metallic Thread and Cord
- Wavy Rotary Cutter
- Ruler
- Cutting Mat
- Spray Sizing